



HIGH-SPEED DOORS

NEW. Economical high-speed door V 5025 Z with flexible door curtain and zipper technology

HÖRMANN





4



20



36

Content

- 4 **Good reasons to try Hörmann**

- 20 **Application areas**
 - 22 Insulated external doors
 - 24 Robust external doors
 - 26 Flexible internal doors
 - 30 Internal doors for cold store and deep freeze areas
 - 32 Internal doors for retail and the food industry
 - 34 Internal doors for individual requirements

- 36 **Versions, accessories, technology**
 - 38 Turbo spiral doors
 - 40 Spiral doors and high-speed sectional doors HS
 - 44 High-speed sectional door IsoSpeed Cold 100
 - 48 Flexible internal and external door with zipper technology
 - 50 Flexible internal and external doors
 - 52 Flexible internal doors with SoftEdge bottom profile
 - 56 Flexible internal doors
 - 62 High-speed folding doors
 - 66 Individual colour schemes
 - 68 Controls
 - 72 Accessories

Brand quality made in Germany



The family-owned company Hörmann offers all important construction components for building and renovating projects from a single source. We manufacture in highly specialised factories using state-of-the-art production technologies. Our employees work intensively on new products, continual further developments and improvements to details. The results are patents and unique products on the market.





WE THINK AND ACT GREEN. As a family business, we are very conscious of our responsibility to future generations and will offer all products for construction projects as CO₂-neutral versions upon customer request. In this way, customers have the option to offset remaining emissions and make a contribution to climate protection when purchasing our products. The Hörmann sustainability strategy aims to reduce and avoid emissions. We cover 100% of our electrical power needs at all European production sites with genuine green electricity from renewable sources (excluding France, where we use electricity generated by nuclear power). We also apply many other measures to reduce our consumption and save more than 75000 tonnes of CO₂ each year. We work with ClimatePartner to offset the remaining emissions by supporting certified climate protection projects.



You can find further information at www.hoermann.com/sustainability



ClimatePartner
certified product
climate-id.com/FYZNUF



CO₂
measure
reduce
contribute

Sustainable planning for trend-setting construction

Experienced specialists within our customer-oriented sales organisation accompany you from the planning stage, through technical clarification up to the final building inspection. Complete working documentation, such as technical manuals, is always accessible and up-to-date at www.hoermann.com





SUSTAINABILITY DOCUMENTED. Hörmann has already received confirmation of sustainability through an Environmental Product Declaration (EPD) in accordance with ISO 14025 from the Institut für Fenstertechnik (ift – Institute of window technology) in Rosenheim, Germany. This EPD was created based on EN ISO 14025:2011 and EN 15804:2012.

In addition, the general guidelines for the preparation of type III Environmental Product Declaration apply. The declaration is based on the PCR document “Doors” PCRTT-1.1:2011.



PRODUCT PORTAL. Clearly structured navigation and a search function provide faster access to texts for invitations to tender, technical data, certificates, CAD drawings and much more. In addition, BIM data can be provided for many products for the Building Information Modelling process, enabling efficient planning, drafting, construction and management of buildings. Photos and photo-realistic presentations provide additional information on many products.



We are a member of the professional association for digital building products in the Federal Association of Building Systems e.V.



Easy to fit and service

On doors with light grilles integrated in the side elements, no surface-mounted installations (e.g. closing edge safety device or photocell) are required on the door. This makes Hörmann high-speed doors both economical and sustainable.





Round-the-clock service

FAST SERVICE. Our teams of highly qualified specialists travel all around Germany. But Hörmann also offers consulting, maintenance and repairs in many other countries. Our network of over 500 service technicians guarantees speed and flexibility. We are available around the clock. Our customers can rely on us.



10-year guaranteed availability

HÖRMANN SPARE PARTS. It goes without saying that spare parts for doors, operators, and controls are original Hörmann parts that come with a guaranteed availability of 10 years.



Easy connection

PLUG-IN CONTROL WIRING. Thanks to colour-coded plug-in connections and cables, accessory components and safety equipment are easy to connect. This makes fitting for initial electrical start-up quick and easy.

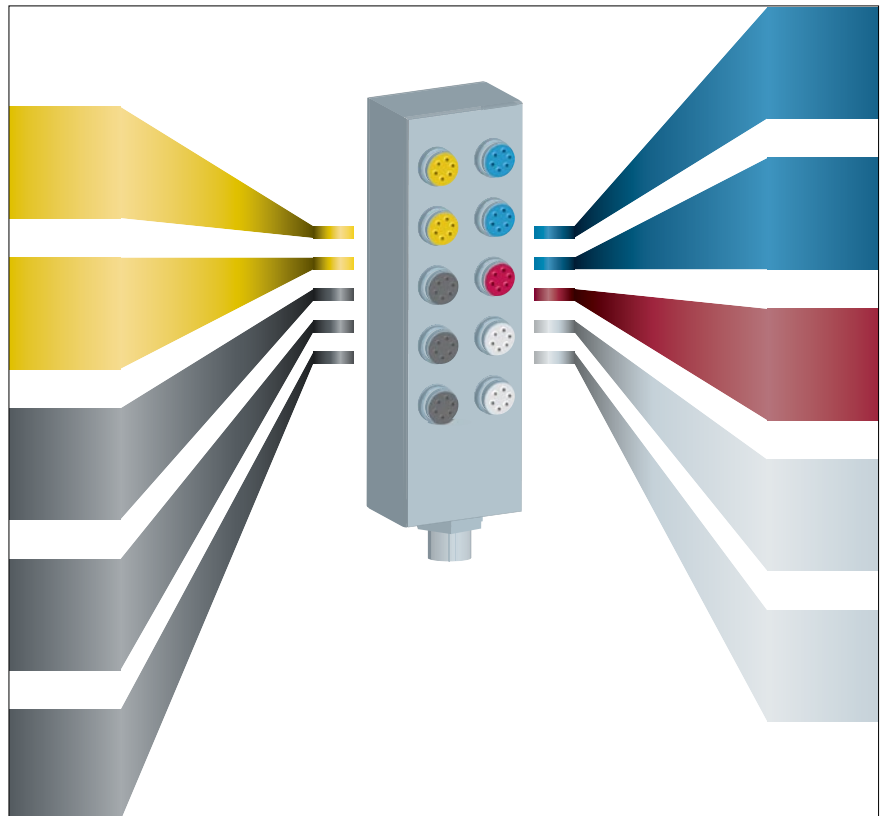

Optimised logistics processes

The high opening and closing speeds of Hörmann high-speed doors significantly speed up work processes and considerably reduce thermal losses and draughts. The standard frequency converter control for spiral doors, high-speed sectional doors and flexible high-speed doors* takes stress off the entire mechanical door elements, guaranteeing nearly wear-free, quiet door travel. Hörmann high-speed doors therefore impress with their long service life and a high level of efficiency.



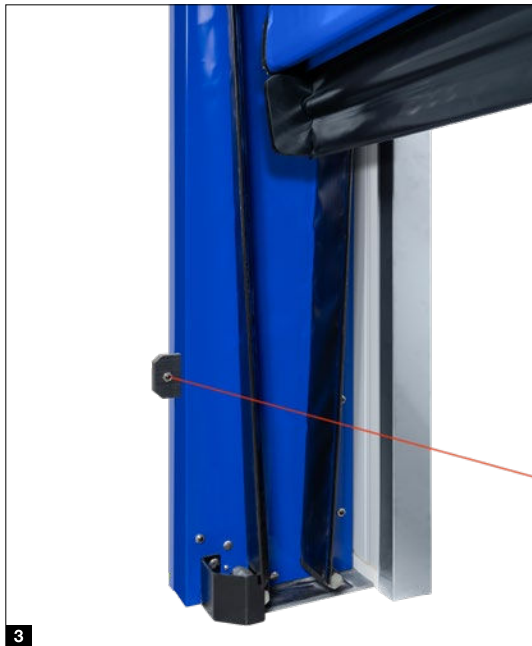

NON-CONTACT SAFETY. On spiral doors, high-speed sectional doors and flexible high-speed doors, the safety light curtain with emergency stop / soft stop function **1** integrated in the side elements monitors the closing zone of the door leaf up to a height of 2500 mm and ensures compliance with the safety requirements according to DIN EN 13241-1. The minimal spacing of the light beams of only 45 mm and the separate diagnosis of the individual light beams with automatic end-of-travel position correction ensure reliable function and increased safety. Furthermore, the gentle emergency-stop / soft stop function slowly stops the door if it encounters an obstacle and there is sufficient remaining travel.

On the F 6010 / F 6010 Iso high-speed folding doors, a safety light curtain integrated in the side elements **2** also monitors the closing zone of the curtain up to a height of 2500 mm. The door types F 8005, F 14005 and F 4010 Cold are fitted with a photocell **3** for monitoring the closing zone. These safety devices also meet the requirements of DIN EN 13241-1.

* Not with V 3010, V 4008 SEL, V 10008, V 2012, V 3009 Conveyor and V 3015 Clean (with relay control)

Currently the fastest vertically opening industrial high-speed door*

The new generation of external and internal doors opens at a record speed of over 4.0 m/s – tested and confirmed by the Record Institute for Germany. The very high and impact-resistant polycarbonate sections with a transparency of 90% of the door leaf surface are very durable and easily withstand the demands of a harsh industrial environment.





Only from Hörmann



Opening speed over 4.0 m/s

Only from Hörmann



Approx. 90% transparent door leaf surface



Service-friendly

DOOR OPENING AT RECORD SPEED. The HS 5040 TurboLux S door version opens faster than 4.0 m/s. This minimises the waiting times of transport vehicles in front of the door, so that forklift trucks, for example, can drive through the door without stopping.

MAXIMUM TRANSPARENCY. The particularly high door sections with a height of 550 mm offer generous visibility without vertical rails with a transparency of 90% of the door leaf surface. This makes for a bright and friendly working environment and safe transport routes.

LESS MAINTENANCE WORK REQUIRED. The HS 5040 TurboLux door version with counterbalance implemented by counter weights is extremely low-wearing, since there is no need to replace the springs every 100000 cycles. This makes the HS 5040 TurboLux virtually wear-free and greatly reduces maintenance costs.

→ For further information, see from page 38.

* As at 13 November 2024, confirmed on 5 August 2024 by the Record Institute for Germany

Spiral doors and high-speed sectional doors

Depending on the version, the galvanized, double-skinned sections are guided in a spiral or in tracks at a speed of up to 2.5 m/s. The sturdy steel sections of the doors have thermal breaks and are PU-foamed. As a result you benefit from excellent thermal values of up to $1.04 \text{ W}/(\text{m}^2 \cdot \text{K})$ and minimise energy loss.





RC2 security features
Tested and certified

RC2 SECURITY AS STANDARD. Spiral doors HS 7030 PU 42, HS 5012 PU 42 S and the high-speed sectional door HS 5015 PU N 42 are tested and certified as standard in resistance class RC2 in accordance with the DIN/TS 18194 standard and impress as a secure hall closure not only at night.



Duratec
Extremely scratch-resistant

OPTIONAL GLAZING. Duratec glazing guarantees maximum scratch resistance despite heavy use in rough industrial environments. The special surface coating protects the pane from scratches and damage caused by cleaning.



Service-friendly
Thanks to counterbalance via counter weights

LESS MAINTENANCE WORK REQUIRED.

The HS 7030 PU 42 door version is equipped with counterbalance via counter weights up to a door size of 5000 mm width and / or 5000 mm height and convinces with low wear and greatly reduced maintenance costs.

NEW. ELEGANT PROTECTION. The optional shaft cover made of impact-resistant polycarbonate protects the internal drive unit of spiral doors from soiling. Its lightweight design makes it very easy to fit and service.



→ For further information, see from page 40.



Watch the video on YouTube or
www.hormann.co.uk/media-centre

Flexible high-speed doors

Thanks to the standard frequency converter control, flexible high-speed doors offer an impressive service life. In addition, they are low-maintenance, easy to fit, cost-efficient and therefore economical for daily use. The anti-crash function and the safety light curtain on high-speed doors with SoftEdge profile or zipper technology prevent door system downtimes and ensure trouble-free operation and production processes.





NEW. Reliable anti-crash function with the V 5025 Z thanks to zipper technology



No downtimes resulting from a crash thanks to the innovative SoftEdge bottom profile

NEW. HIGH-SPEED DOOR V 5025 Z WITH ZIPPER

TECHNOLOGY. The door curtain is connected to the side elements by a zipper system. In the event of a crash, this zipper opens over the entire clear passage height to reliably protect even goods that stand tall. The curtain can then be reinserted fully automatically on both sides of the door.

→ For further information on flexible internal and external doors with zipper technology, see from page 48.

HIGH-SPEED DOORS WITH SOFTEGE PROFILE. In the event of a crash, the innovative bottom profile is pushed out of the side guides and the door is stopped instantly by the integrated radio crash switch. The curtain can then be reinserted on one side of the door and the door can be operated again. Extensive repairs, such as those with rigid bottom profiles, usually do not become necessary.

→ For further information on flexible internal doors with SoftEdge bottom profile, see from page 52.



Watch the video on the SoftEdge bottom profile on YouTube or at www.hormann.co.uk/media-centre

Flexible high-speed folding doors

This door construction excels as an external door capable of withstanding high wind loads. It can be fitted either on the inside or the outside of the opening. The curtain is opened using a patented belt system with safety belts and folds in the lintel area. The galvanised steel wind reinforcement laths are arranged across the entire door height and withstand wind loads up to class 4 (optional).



NO DOWNTIMES RESULTING FROM A CRASH. The robust frame with innovative flexible guide belts* prevents damage and resulting downtimes of the door system. In the event of a crash, the floor rail of the curtain is forced out of the guide belts. The curtain can then be reinserted and the door can be operated again. Another advantage of the flexible guide belts is minimal noise during movement of the curtain and the wind reinforcement laths caused by the wind.

* For F 4010 Cold, F 6010, F 6010 Iso

ANTI-FALL SAFEGUARD AS STANDARD. The high-speed folding doors are opened and closed via two pull belts. In addition, two further safety belts secure the door curtain in the event of damage, e.g. tearing of the pull belts. This patented belt system effectively prevents the door from crashing.

→ For further information, see from page 62.

No downtime after a crash thanks to the innovative flexible guide belts



Standard anti-fall safeguard thanks to two additional safety belts

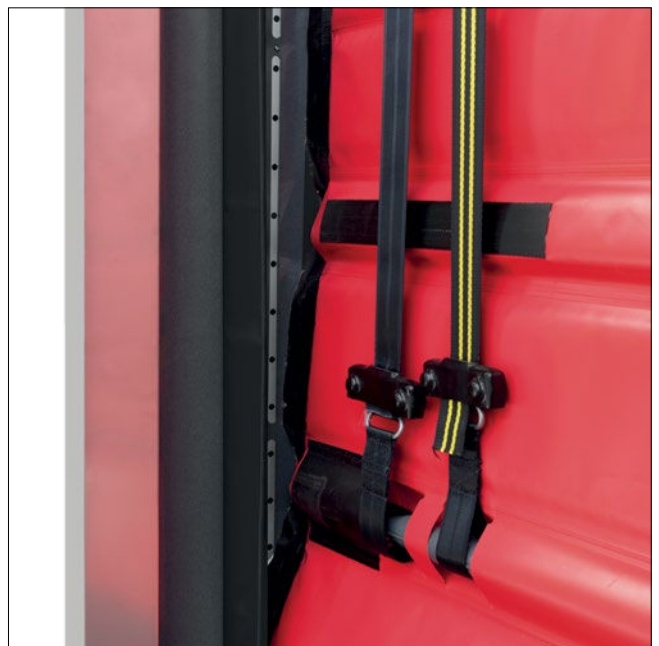





Application areas

- 22 Insulated external doors
- 24 Robust external doors
- 26 Flexible internal doors
- 30 Internal doors for cold store and deep freeze areas
- 32 Internal doors for retail and the food industry
- 34 Internal doors for individual requirements

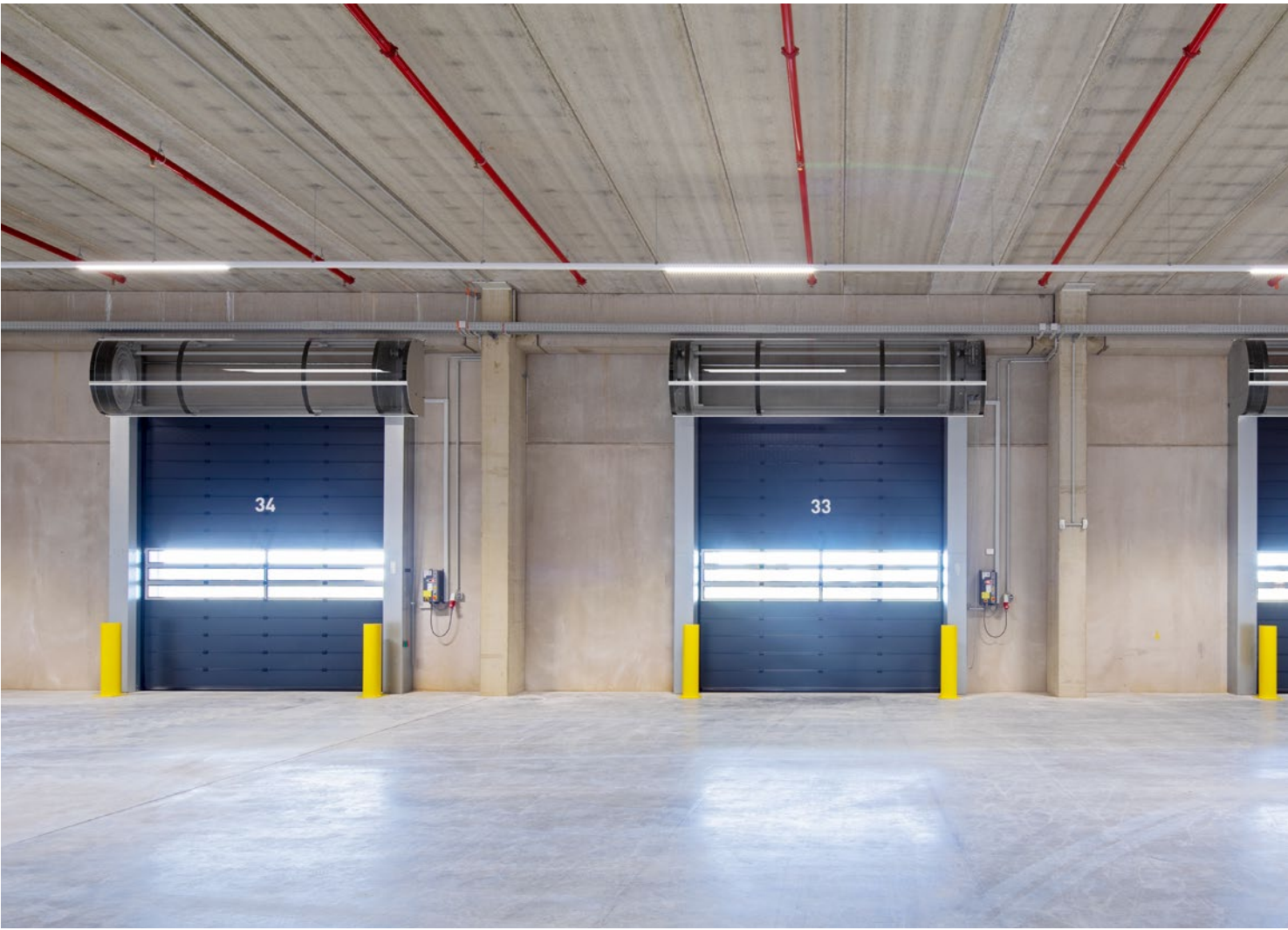

TOP LEFT. Spiral door HS 7030 PU 42

BOTTOM. High-speed sectional door HS 5015 PU N 42

TOP RIGHT. High-speed sectional door HS 5015 PU V 42



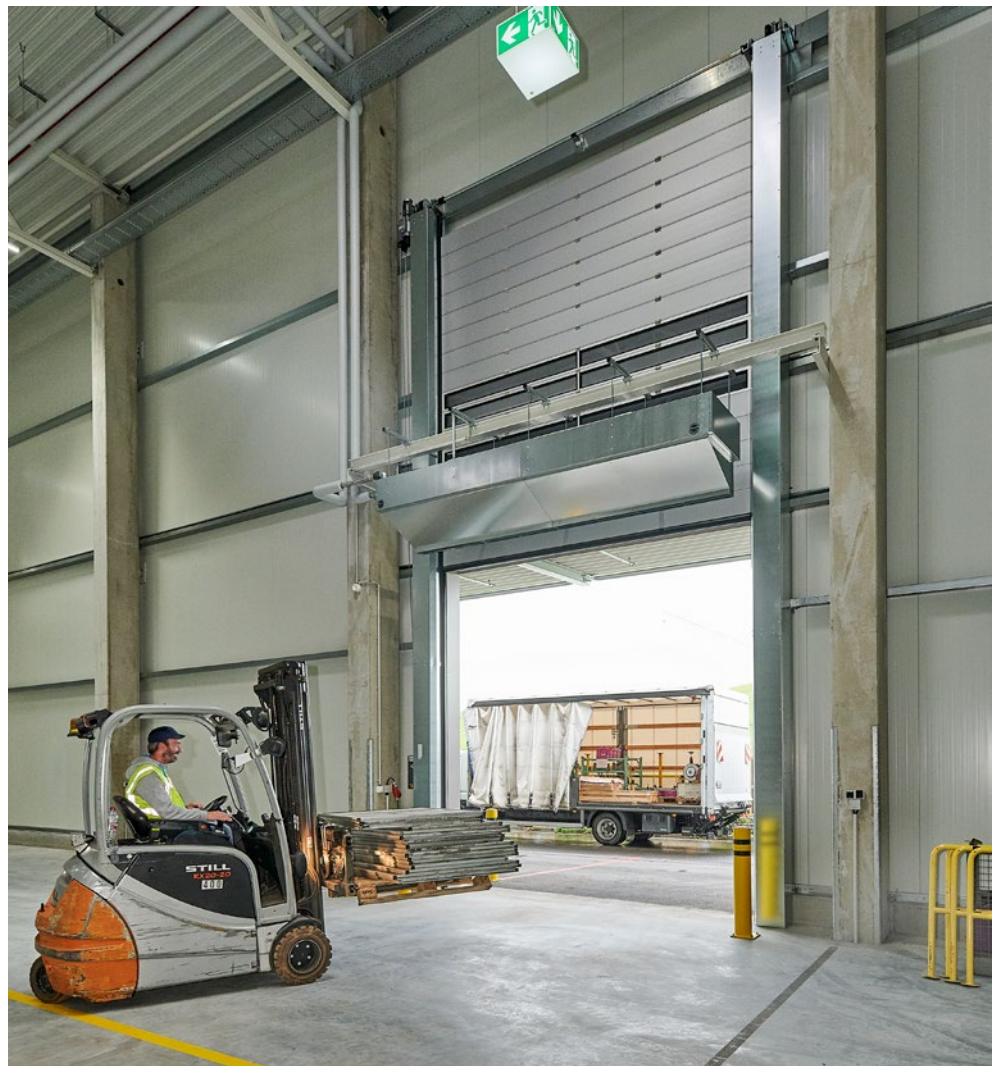

Insulated external doors

The spiral and high-speed sectional doors consisting of steel sections with thermal breaks reduce energy losses thanks to their fast opening speeds and convince as secure and very well insulated night doors. Depending on the version, the sections are guided in a spiral or in tracks.

→ For further information, see from page 40.

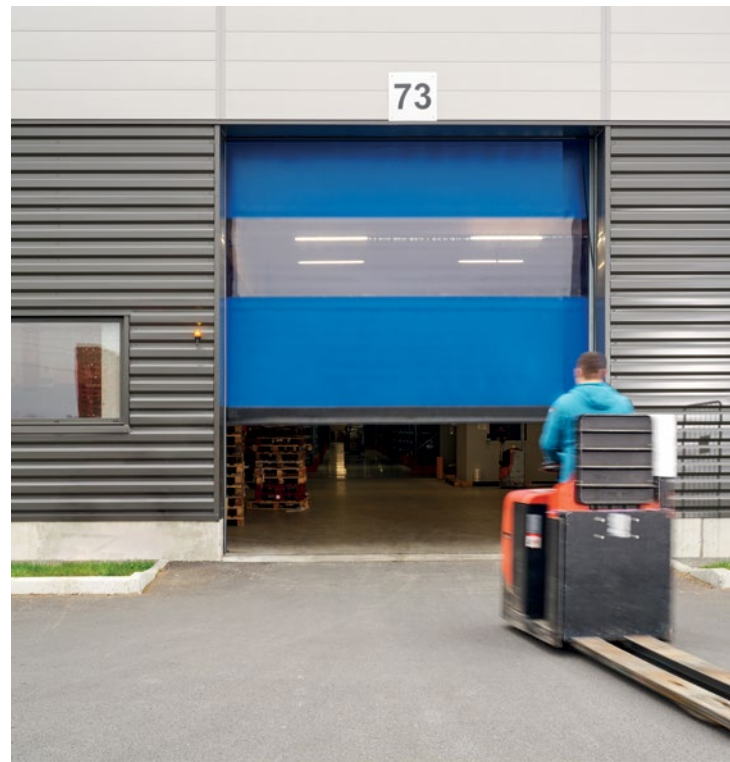
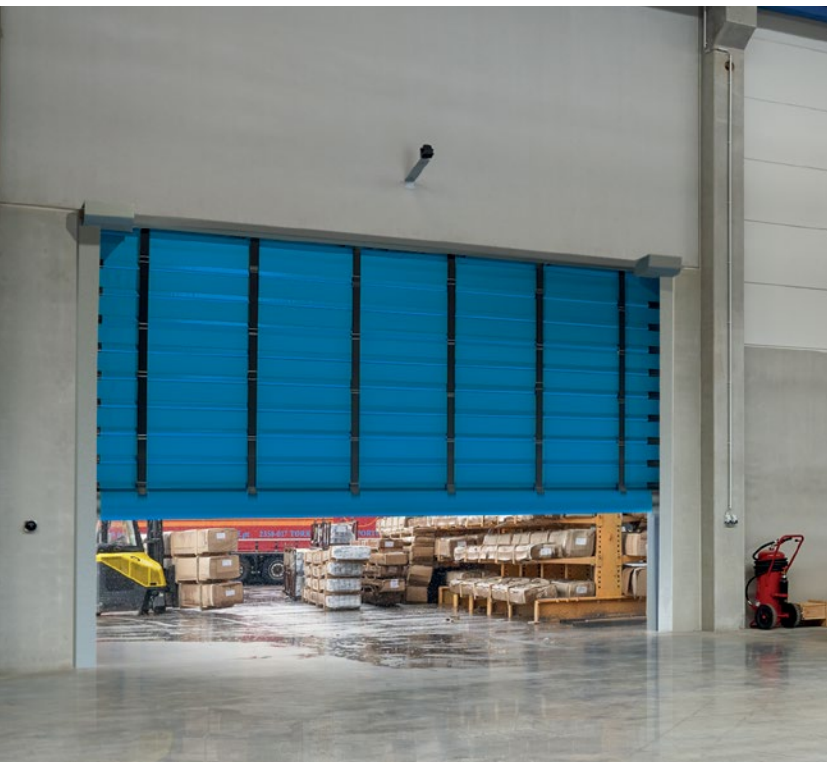

Robust external doors

The flexible high-speed doors and high-speed folding doors easily withstand wind loads and reduce energy losses as well as draughts. The V 10008 high-speed door and the F 8005 and F 14005 high-speed folding doors are specifically developed for large openings and high wind loads of up to 100 km/h.

- For further information on turbo spiral doors, see from page 38.
- For further information on flexible internal and external doors, see from page 50.
- For further information on high-speed folding doors, see from page 62.





TOP LEFT. High-speed folding door F 14005 with an operator on both sides

TOP CENTRE LEFT. High-speed door V 6030 SEL

TOP RIGHT. High-speed door V 10008

BOTTOM. Turbospiral door HS 5040 TurboLux



Flexible internal doors

Thanks to the high opening and closing speeds, heat losses as well as draughts at the workplace are noticeably reduced, resulting in less work absences due to illness. Vision fields or fully transparent curtains make for a bright and friendly working environment and provide visibility for safe transport routes.

- For further information on turbo spiral doors, see from page 38.
- For further information on flexible internal doors with SoftEdge bottom profile, see from page 52.
- For further information on high-speed folding doors, see from page 62.

TOP. Turbo spiral door HS 5040 TurboLux
BOTTOM LEFT. High-speed door V 5030 SEL
BOTTOM RIGHT. **NEW.** High-speed door V 5025 Z

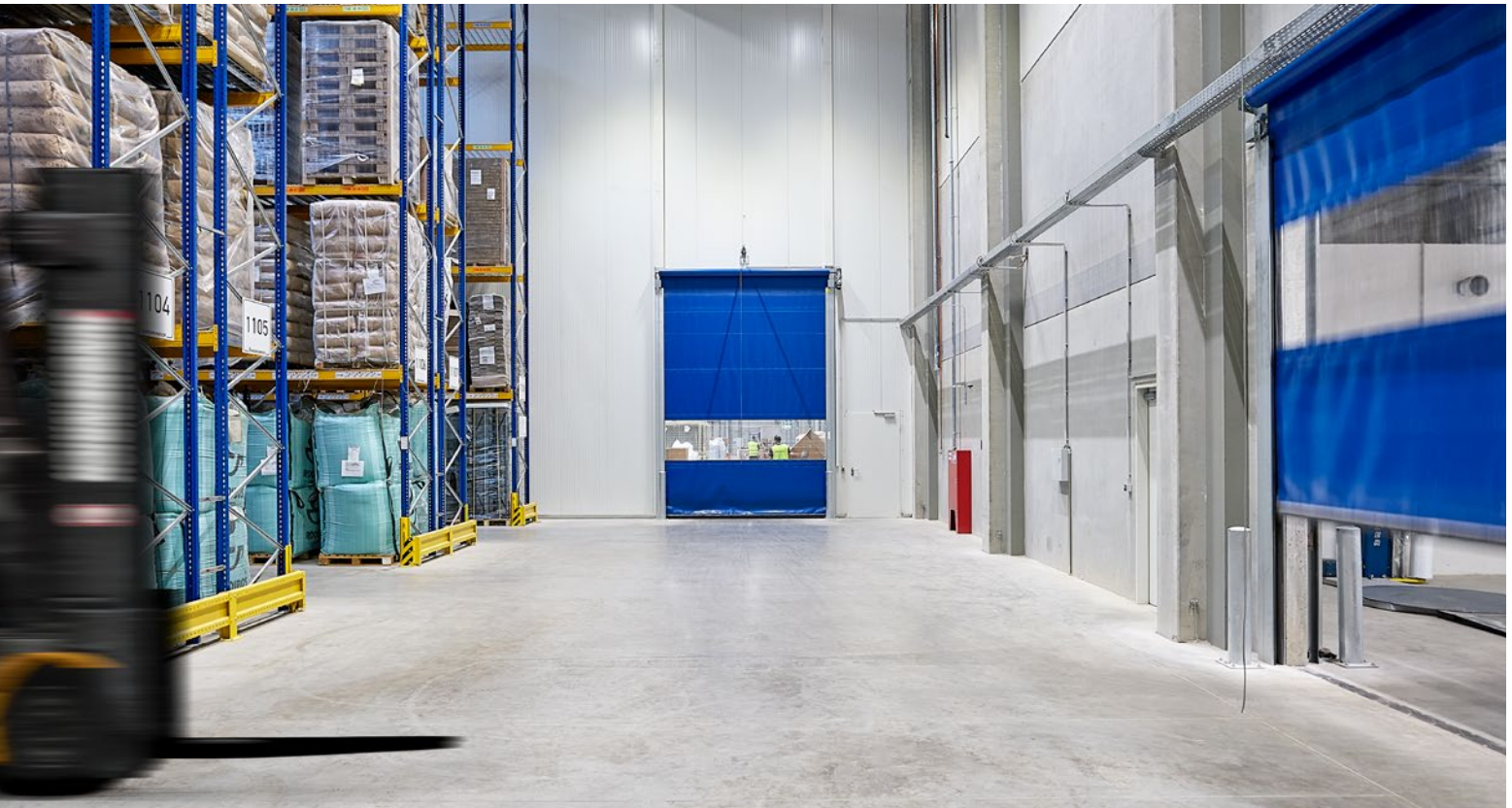

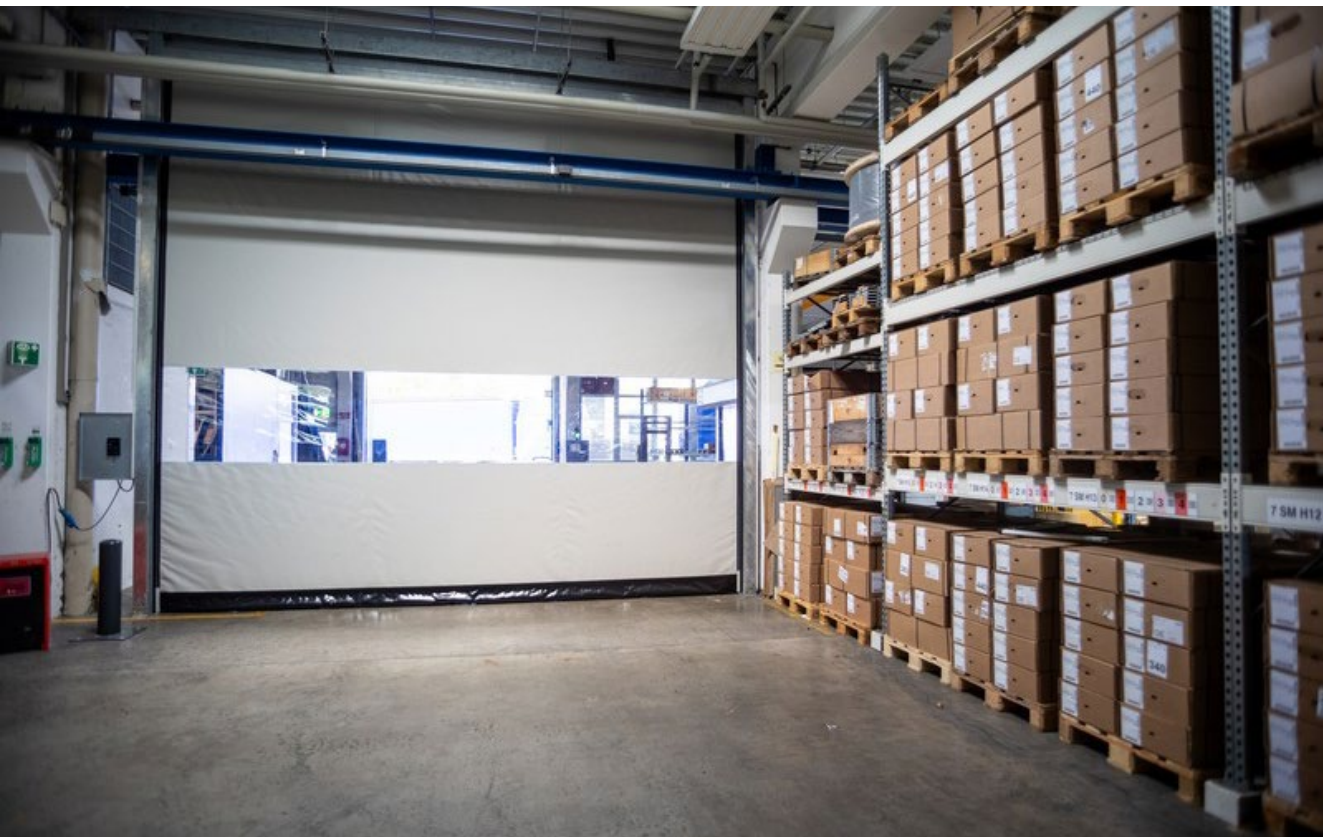

TOP LEFT. High-speed folding door F 8005

BOTTOM LEFT. Optimum combination of high-speed door V 5030 and PE double-action door HPP-180 for pedestrian passage

TOP RIGHT. High-speed door V 6030 SEL

BOTTOM RIGHT. High-speed door V 6030 SEL



For further information on double-action doors, see the brochure.





TOP. High-speed sectional door IsoSpeed Cold H 100 and **NEW**. Insulating hinged and sliding doors

BOTTOM LEFT. High-speed door V 4020 Cold

BOTTOM CENTRE. High-speed folding door F 4010 Cold

BOTTOM RIGHT. High-speed door V 4015 Iso L





Internal doors for cold store and deep freeze areas

The IsoSpeed Cold 100 high-speed sectional door, the V 4015 Iso L and V 4020 Cold high-speed doors and the F 4010 Cold high-speed folding door are the ideal solutions for various applications in the cold store and deep freeze logistics sectors. Their sections with thermal breaks and insulated curtains reliably reduce cold losses in deep freeze areas. Opening speeds up to 2 m/s ensure rapid traffic flow to maintain the cold chain.

- For further information on the high-speed sectional door IsoSpeed Cold 100, see from page 44.
- For further information on flexible internal doors, see from page 58.
- For further information on high-speed folding doors, see from page 62.



TOP LEFT. High-speed door V 3010
TOP CENTRE. High-speed door V 2515 Food L
TOP RIGHT. Easy cleaning of the
high-speed door V 2515 Food L
BOTTOM LEFT. High-speed door V 2012
with custom imprint





Internal doors for retail and the food industry

The space-saving V 2012 and V 3010 doors are specially designed as safe internal doors in commercial enterprises with high customer traffic. Specifically designed for use in the food industry, the door types V 2515 Food L and V 3010 are made entirely of stainless steel. They can be cleaned very easily using high-pressure cleaners.

→ For further information, see from page 56.

Internal doors for individual requirements

Various demands require individual door solutions. Based on our expert know-how, we develop customer-specific solutions for special application areas such as conveyor systems, clean rooms or for machine safety.

→ For further information, see from page 60.





TOP. High-speed door V 3009 Conveyor
BOTTOM LEFT. High-speed door V 4020 Protect
BOTTOM CENTRE. High-speed door V 5030 MSL
BOTTOM RIGHT. High-speed door V 3015 Clean





Versions Accessories Technology

- 38 Turbo spiral doors
- 40 Spiral doors and high-speed sectional doors HS
- 44 High-speed sectional door IsoSpeed Cold 100
- 48 Flexible internal and external door with zipper technology
- 50 Flexible internal and external doors
- 52 Flexible internal doors with SoftEdge bottom profile
- 56 Flexible internal doors
- 62 High-speed folding doors
- 66 Individual colour schemes
- 68 Controls
- 72 Accessories

Turbo spiral doors

Speed and transparency for indoor and outdoor areas

Door type	HS 5040 TurboLux S	HS 5040 TurboLux
Door leaf		
Construction	Impact-resistant polycarbonate sections, divided by aluminium profiles	Impact-resistant polycarbonate sections, divided by aluminium profiles
Depth (mm)	1,5	1,5
Section height (mm)	550	550
Suitable application		
	Interior / exterior	Interior / exterior
Size range		
Max. width (mm)	5000	5000
Max. height (mm)	5000	5000
Min. required headroom (mm)	1200	1200
Control		
Standard	BK 150 FUE-1	AK 150 FUE-1
Safety		
Light grille with emergency stop / soft stop function	●	●
Speed		
Max. opening (m/s)	> 4,0	3,5
Closing approx. (m/s)	1,0	1,0
Resistance to wind load (EN 12424)		
Class 2	●	●
Class 4	○	○
Counterbalance		
Counter weight	-	●
Springs	●	-
Emergency opening / closing		
Emergency hand chain	●	●
Secured release	●	-

● = Standard ○ = Optional



Only from Hörmann

Currently the fastest vertically opening industrial high-speed door*

HS 5040 TurboLux S – opening speed over 4.0 m/s

90% transparent door leaf

HS 5040 TurboLux / HS 5040 TurboLux S

Counterbalance via counter weights

HS 5040 TurboLux

HS 5040 TurboLux S – currently the fastest vertically opening industrial high-speed door* with maximum transparency

The fastest turbo spiral door in the world opens at a record speed of over 4.0 m/s, while featuring a particularly quiet door travel. Fast opening minimises operating costs by reducing waiting times in front of the door and speeding up logistics processes.

HS 5040 TurboLux – with maximum transparency and low maintenance costs

Hörmann is the only manufacturer to use counter weights instead of springs for counterbalance on the HS 5040 TurboLux. This makes the door virtually wear-free and greatly reduces maintenance costs since it does away with the need for spring replacement after approx. 100000 door cycles.

Maximum transparency

The high-speed door leaf features a transparency of approx. 90%. The impact-resistant polycarbonate sections **1** are very sturdy and easily withstand the demands of a harsh industrial environment.

Space-saving construction

Thanks to the particularly powerful operator fitted on the inside **2** and its very narrow side elements **3**, the high-speed door only requires 275 mm sideroom for fitting.

Shaft cover

The unique transparent shaft cover **4** protects the operating unit on the inside from soiling and harmoniously rounds off the door appearance.

Non-contact safety

The safety light curtain with emergency stop / soft stop function **5** integrated into the side elements monitors the closing zone of the door leaf up to a height of 2500 mm and ensures compliance with the safety requirements according to DIN EN 13241-1.

The minimal spacing of the light beams of only 45 mm and the separate diagnosis of the individual light beams with automatic end-of-travel position correction ensure reliable function and increased safety. Furthermore, the gentle emergency-stop / soft stop function slowly stops the door in the event an obstacle is detected with a sufficient remaining travel distance.

* As at 13 November 2024, confirmed on 5 August 2024 by the Record Institute for Germany



Spiral doors and high-speed sectional doors HS

Thermally insulated and secure building closure

Steel sandwich section with thermal break

The 42 mm thick PU-foamed steel sections **1** are delivered with elegant Micrograin surface **3** on the exterior and Stucco surface **4** on the interior – exterior and interior are White aluminium based on RAL 9006 as standard.

Door types

HS 7030 PU 42 – with RC2 security features as standard and low maintenance costs

HS 5012 PU 42 S – with RC2 security features as standard for confined spaces

HS 5015 PU N 42 – with RC2 security features as standard and little required headroom

HS 5012 PU N 42 S – with little required headroom and little sideroom either side

HS 5015 PU H 42 – for special fitting situations and with low maintenance costs

HS 6015 PU V 42 – with very quiet and wear-free door travel and low maintenance costs

Acoustic sections

For the special requirements of acoustic insulation, the Acoustic high-speed doors are equipped with aluminium hollow profiles **2**. The hollow profiles are filled with 5 mm UPVC and 30 mm PU foam.

Door types

HS 7030 Acoustic – for the special requirements placed on acoustic insulation

HS 5015 Acoustic H – for the special requirements placed on acoustic insulation and for special fitting situations

HS 6015 Acoustic V – for the special requirements placed on acoustic insulation and with very quiet and wear-free door travel

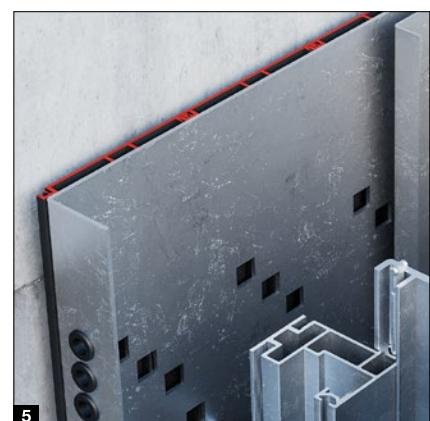
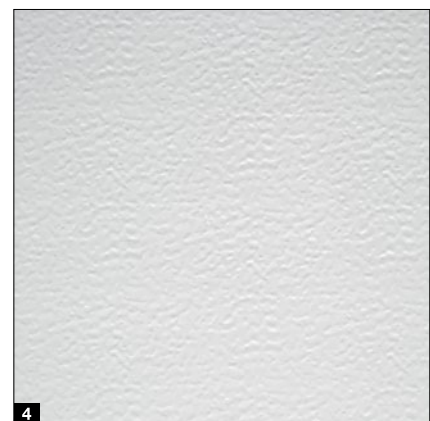
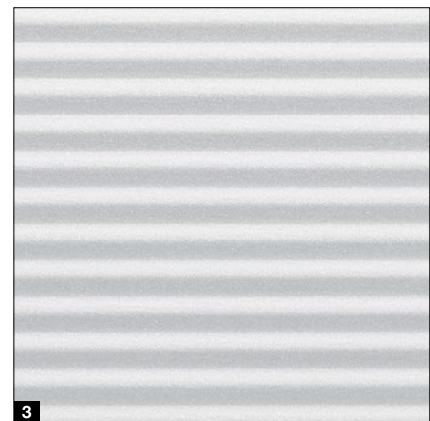

Increased thermal insulation thanks to ThermoFrame

Well-insulated high-speed doors are essential in heated halls. The ThermoFrame **5** separates the side element from the building structure. The thermal break along with additional seals improves thermal insulation by up to 15% and is easy and quick to fit. The ThermoFrame is optionally available for doors with 42 mm thick sections.

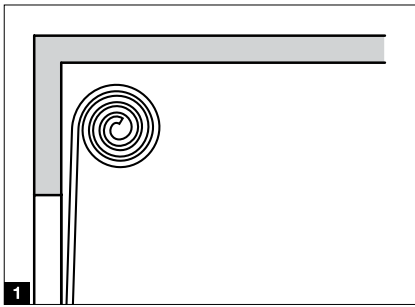

The compact spiral track application 1

The sections are securely guided into a spiral bracket without any contact. With the high-performance frequency converter control (FU), the door reaches an opening speed of up to 2.5 m/s. The HS 7030 PU 42 spiral door with chain mechanism and counterbalance can also be fitted externally (max. door size 5 × 5 m, max. 5 glazing sections). This track application is also available with narrow side elements (see below).

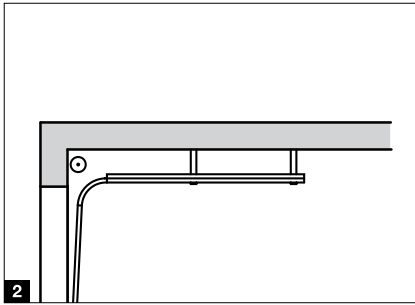

The space-saving track application N 2

We recommend this track application for tight spaces in the lintel area. A chain mechanism with spring compensation runs the sections into horizontal tracks. This requires a low headroom of only 480 mm. This track application is also available with narrow side elements (see below).

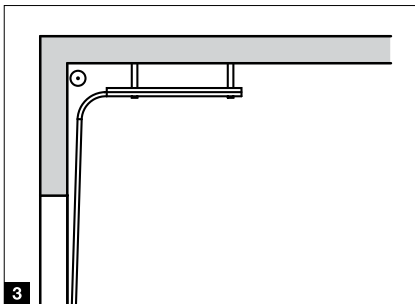

The adjustable track application H 3

The sections are guided into horizontal tracks and can be diverted depending on the fitting situation. Thus, the door can be fitted behind or above supply lines and crane tracks. Thanks to the belt mechanism with counter weights, the door is especially low-wear and durable.

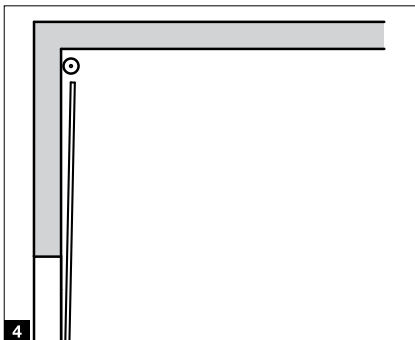

The wear-free track application V 4

The sections run vertically along the hall wall. That is why the door movements are very quiet and wear-free. The belt mechanism with counter weights guarantees a long service life with constant use.

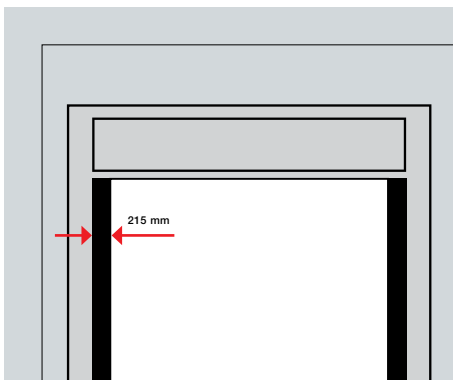

Spiral track application and track application N with narrow side elements

Spiral doors HS 5012 PU 42 S and **NEW.** HS 5012 PU N 42 S with 215 mm instead of 330 mm narrow side elements allows for fitting even in confined spaces. Thanks to their operator without counterbalance the doors even feature a double advantage: low purchase price and low service and maintenance costs.

Spiral doors and high-speed sectional doors HS

Overview

Door type	HS 7030 PU 42	HS 5012 PU 42 S	HS 7030 Acoustic	HS 5015 PU N 42
Door hardware	Spiral track application	Spiral track application	Spiral track application	Track application N (normal)
Door leaf				
Construction	Steel sandwich construction, PU-foamed	Steel sandwich construction, PU-foamed	Aluminium hollow profile, 5 mm UPVC / 30 mm PU	Steel sandwich construction, PU-foamed
Depth (mm)	42	42	42	42
Section height (mm)	250	250	225	250
Exterior / interior surface	Micrograin / Stucco	Micrograin / Stucco	smooth	Micrograin / Stucco
Standard colour	RAL 9006	RAL 9006	C0 anodised	RAL 9006
ThermoFrame	○	○	–	○
Duratec glazing, double	○	○	–	○
Suitable application	Interior / exterior	Interior / exterior	Interior / exterior	Interior / exterior
Size range				
Max. width (mm)	8000	5000	5000	5000
Max. height (mm)	6500	5000	5000	6500
Min. required headroom (mm)	920	920	1000	480
Speed				
Max. opening (m/s)	1,2 – 2,5	1,2	1,5 – 2,5	1,5 – 2,5
Closing approx. (m/s)	0,5	0,5	0,5	0,5
Control				
Standard	AK 500 FUE-1	AK 500 FUE-1	AK 500 FUE-1	AK 500 FUE-1
Safety				
Light grille with emergency stop / soft stop function	●	●	●	●
Thermal insulation U-value¹⁾ in W/(m²·K) (EN 13241-1, ISO 12567-1)	1,04	1,04	–	1,04
Resistance to wind load (EN 12424)				
Door width ≤ 5000 mm	Class 5	Class 5	Class 4	Class 5
Door width > 5000 mm ≤ 6000 mm	Class 4	Class 4	–	Class 4
Door width > 6000 mm	Class 2	Class 2	–	Class 2
Resistance to water penetration (EN 12425)	Class 1	Class 1	–	Class 1
Air permeability (EN 12426)	Class 2	Class 2	–	Class 2
Acoustic insulation²⁾ in dB (EN 717-1, EN ISO 10140-1, EN ISO 10140-2)	26	26	31	26
RC2 break-in resistance equipment (acc. to DIN/TS 18194)	● ³⁾	● ³⁾	–	●
Counterbalance				
Chain mechanism and springs	●	–	●	●
Belt mechanism and counter weights	■	–	–	–
without counterbalance	□	●	–	–
Emergency opening				
Emergency hand chain	●	●	●	●
Automatic door opening via UPS in case of power failure	○ ⁴⁾	–	–	○ ³⁾

● = Standard

○ = Optional

■ = Standard up to 5000 mm width and 5000 mm height

□ = Standard up to 3000 mm width and 3000 mm height LDH = clear passage height

¹⁾ Door size 4000 × 4000 mm, without glazing with ThermoFrame

²⁾ Without glazing

³⁾ With glazing

⁴⁾ Counterbalance via springs

NEW. HS 5012 PU N 42	HS 5015 PU H 42	HS 5015 Acoustic H	HS 6015 PU V 42	HS 6015 Acoustic V
Track application N (normal)	Track application H (high-lift)	Track application H (high-lift)	Track application V (vertical)	Track application V (vertical)
Steel sandwich construction, PU-foamed 42 250 Micrograin / Stucco RAL 9006 ○ ○	Steel sandwich construction, PU-foamed 42 250 Micrograin / Stucco RAL 9006 ○ ○	Aluminium hollow profile, 5 mm UPVC / 30 mm PU 42 225 smooth C0 anodised - -	Steel sandwich construction, PU-foamed 42 250 Micrograin / Stucco RAL 9006 ○ ○	Aluminium hollow profile, 5 mm UPVC / 30 mm PU 42 225 smooth C0 anodised - -
Interior / exterior	Interior / exterior	Interior / exterior	Interior / exterior	Interior / exterior
5000 5000 920	5000 6500 750	5000 5000 1000	6500 6500 LDH + 585	5000 5000 LDH + 585
1,2 0,5	1,5 – 2,5 0,5	1,5 – 2,5 0,5	1,5 – 2,5 0,5	1,5 – 2,5 0,5
AK 500 FUE-1	AK 500 FUE-1	AK 500 FUE-1	AK 500 FUE-1	AK 500 FUE-1
●	●	●	●	●
1,04	1,04	-	1,04	-
Class 5 - -	Class 5 Class 4 Class 2	Class 4 - -	Class 5 Class 4 Class 2	Class 4 - -
Class 1	Class 1	-	Class 1	-
Class 2	Class 2	-	Class 2	-
26	26	31	26	31
● ³⁾	-	-	-	-
- - ●	- ● -	- ● -	- ● -	- ● -
● -	● -	● -	● ○ ³⁾	● -

All colours based on RAL

High-speed sectional doors IsoSpeed Cold 100

Excellent insulation for cold store and deep freeze areas (down to max. -28°C)

Door type	IsoSpeed Cold H 100	IsoSpeed Cold V 100
Door hardware	Track application H (high-lift)	Track application V (vertical)
Suitable application	Interior	Interior
Size range		
Max. width (mm)	5000	5000
Max. height (mm)	5000	5000
Min. required headroom (mm)	750	LDH + 585
Speed		
Max. opening (m/s)	1,5 – 2,0	1,5 – 2,0
Closing approx. (m/s)	0,5	0,5
Control		
Standard	AK 500 FUE-1	AK 500 FUE-1
Safety		
Light grille with emergency stop / soft stop function	●	●
Thermal insulation U-value in $\text{W}/(\text{m}^2\cdot\text{K})$ (EN 13241-1, Appendix B EN 12428)		
2000 × 2000 mm ¹⁾	0,90	0,90
3000 × 3000 mm ¹⁾	0,68	0,68
4000 × 4000 mm ¹⁾	0,57	0,57
5000 × 5000 mm ¹⁾	0,50	0,50
Section	0,24	0,24
Temperature range ²⁾	Fitting side $> 0^{\circ}\text{C}$, opposite side max. -28°C Deviating temperatures on request	
Resistance to wind load (EN 12424)	Class 5	Class 5
Resistance to water penetration (EN 12425)	Class 3	Class 3
Air permeability (EN 12426)	Class 3	Class 3
Counterbalance		
Belt mechanism and counter weights	●	●

● = Standard ○ = Optional

¹⁾ Door surface of fitted door

²⁾ Deviating temperatures on request

³⁾ For a door surface of 5000 × 5000 mm

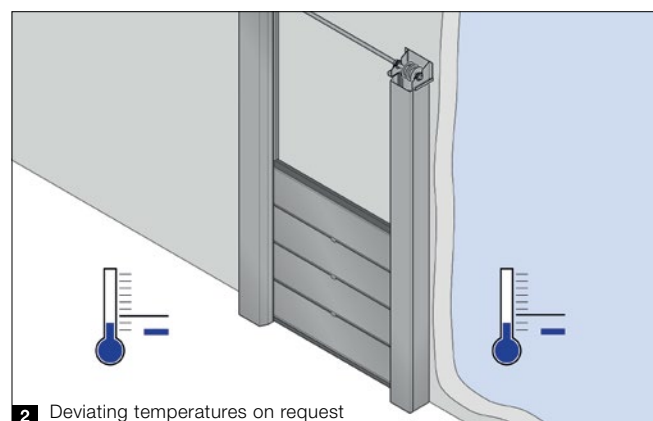
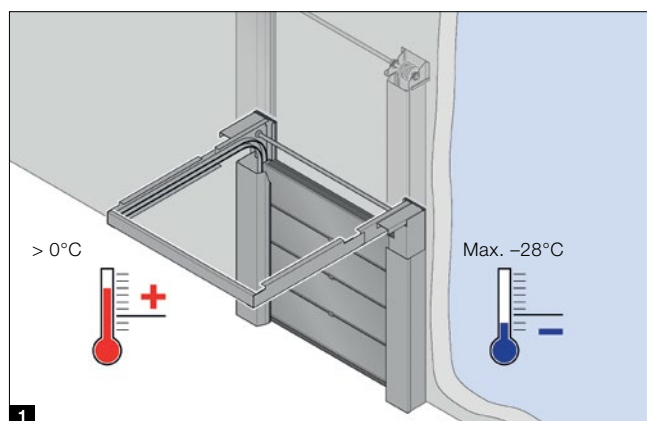



IsoSpeed Cold 100

The IsoSpeed Cold 100 with its 100 mm thick sections with thermal break offers excellent insulation with a U-value of $0.50 \text{ W}/(\text{m}^2 \text{ K})^3$. Doors with a high-lift track application H or vertical-lift track application V are perfectly suited to cold store and deep freeze areas. The sections come Stucco-textured **3** on the interior and exterior, in Grey white based on RAL 9002, optionally also in 200 colours based on RAL.

Door types

IsoSpeed Cold H 100

For special fitting situations and with low maintenance costs

IsoSpeed Cold V 100

With very quiet and wear-free door travel and low maintenance costs

ThermoFrame

The ThermoFrame **4** separates the side element from the building structure. The thermal break along with additional seals improves thermal insulation and prevents thermal bridges.

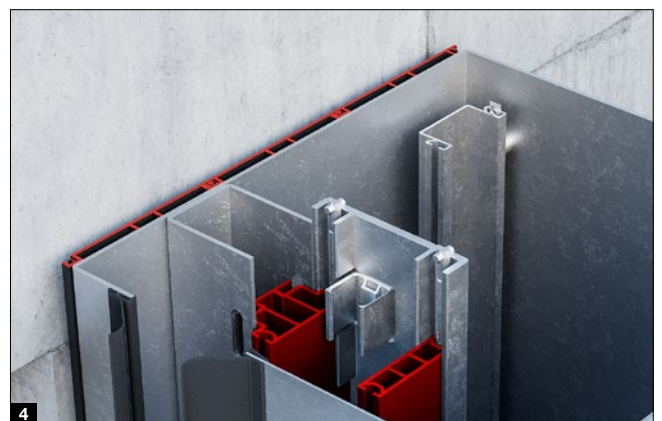
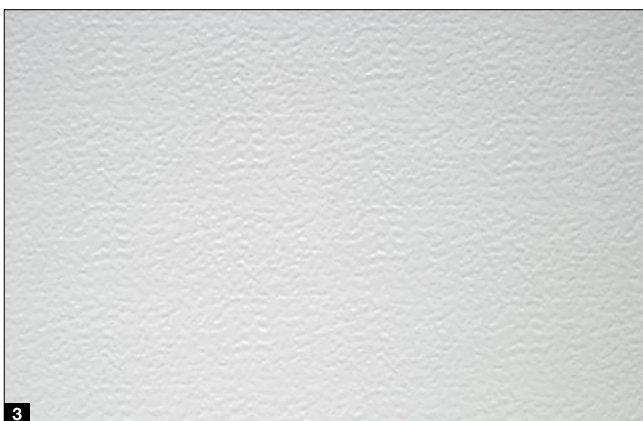

High-speed sectional doors IsoSpeed Cold 100

Excellent insulation for cold store and deep freeze areas (down to max. -28°C)

Standard equipment 1

By using extremely durable flat belts, which are also used in the elevator industry, we guarantee a service life of up to 500000 cycles when fitted properly. Operator support via counter weights also convinces with lower maintenance costs, as no springs have to be serviced.



Frequency converter control 2

High opening and closing speeds guarantee optimised workflows and temperature levels between the cold store and other temperature areas. The soft start and soft stop take stress off the mechanical door elements, enabling nearly wear-free, quiet door travel. This greatly extends the service life of the door.



Integrated heating 3

For safe and reliable operation, the IsoSpeed Cold 100 is equipped with heated side elements, bottom plate, operator, control housing and sealing frame as standard.

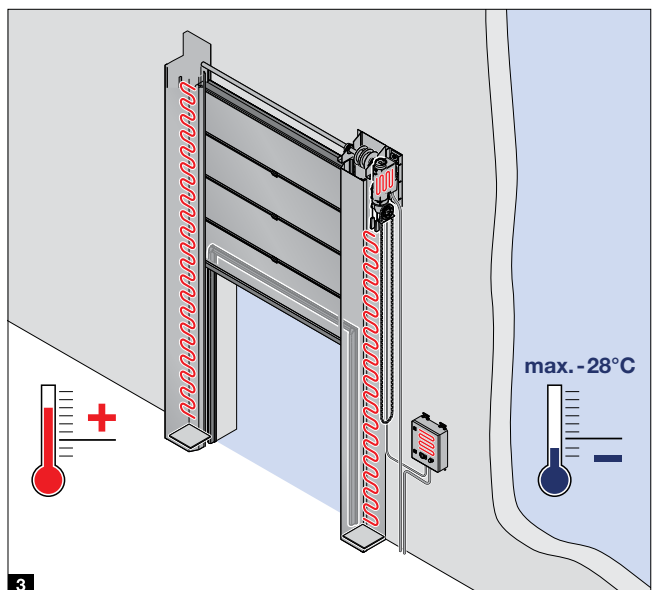

On-site services

Connecting lead for heating **1**

The standard heating in the side elements remains active even when the door main switch is actuated, preventing icing. A second electric cable to the door is required to supply the heating with power.

Road heating **2**

A road heating system effectively prevents the door leaf from freezing. This system is required in the closing zone to cover the entire opening area of the door and the frame depth, as well as approx. another 200 mm.

Air curtain **3**

An air curtain minimises the temperature increase in the deep freeze area. It is installed on the warmer side to effectively reduce the flow of air to the cold side of the opening.

TIP.

Install a cold air curtain, as it is more efficient than a hot air curtain.

Air dehumidifier **4**

For effective reduction of humidity in case of high temperature differences and high humidity, we recommend fitting an air dehumidifier on the warmer side. This minimises ice formation in the deep freeze area.

NOTE.

Please contact the responsible Hörmann regional sales office or your Hörmann sales partner, providing information on temperatures and humidity, for a precise assessment of the fitting situation.

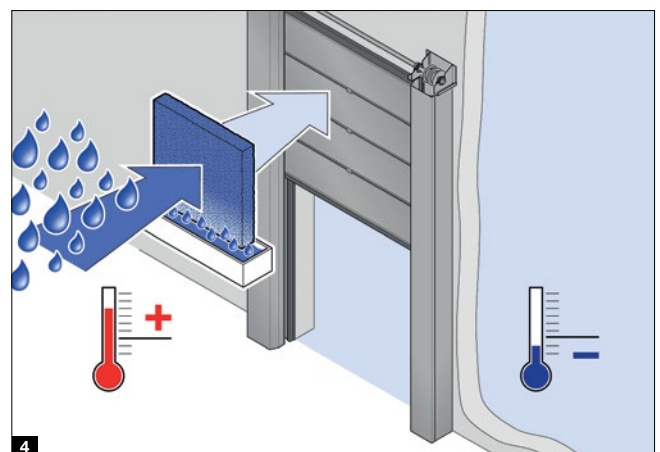
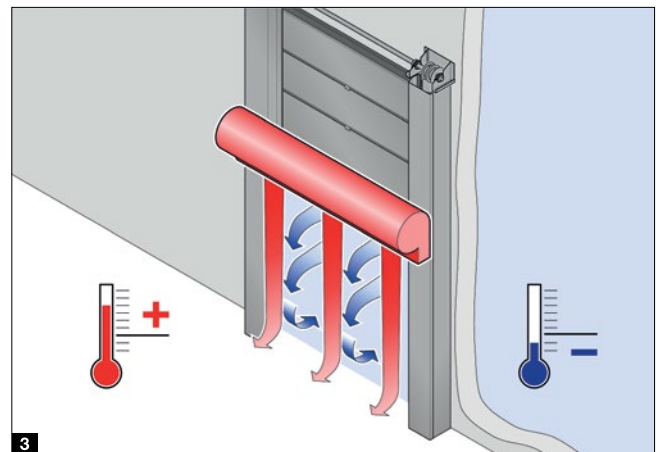
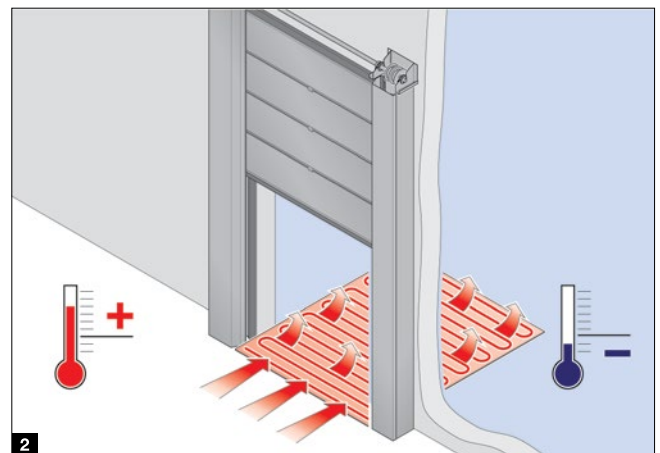
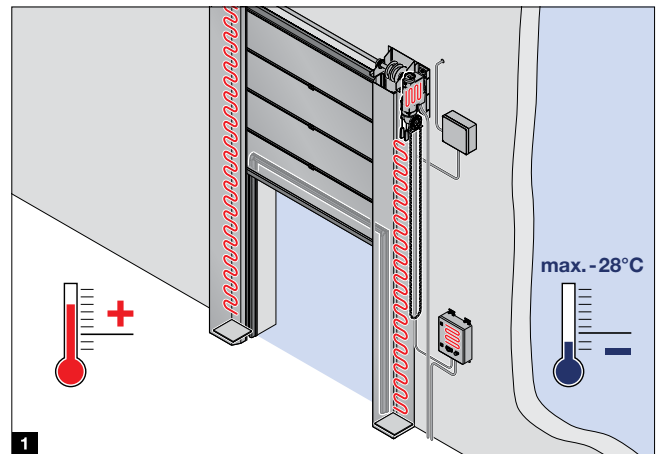

Flexible internal and external door with zipper technology

Fast operational readiness after a crash thanks to automatic re-feed on both sides

Door type	V 5025 Z
Suitable application	Interior
Size range	
Max. width (mm)	5000
Max. height (mm)	5000
Speed	
Max. opening (m/s)	2,0
Closing approx. (m/s)	1,0
Control	
Standard	BK FU Z
Optional	BK 150 FUE-1
Safety	
Light grille	●
Temperature range	+5°C to +40°C
Curtain	PVC
Fabric thickness (mm)	0,9
Vision field thickness (mm)	2,0
Curtain colours	
Standard colours	●
Preferred colours	○
Wind locks	
Zipper technology	●
Bottom profile	
Flexible bottom part	●
Emergency opening	
Service adapter	●
Automatic door opening via UPS in case of power failure	○
Claddings	
Shaft cover	●
Operator cover	○

● = Standard ○ = Optional

All colours based on RAL

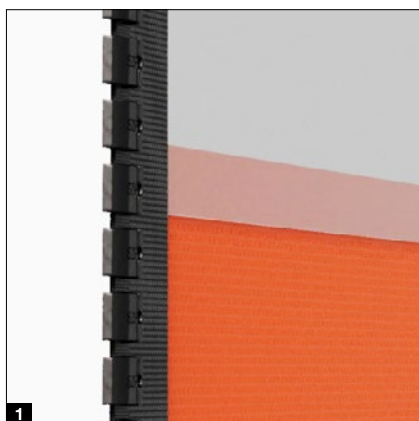

NEW. Door type V 5025 Z

The V 5025 Z is characterised by a reliable crash function with fully automatic re-feed. Prevents downtime due to damage to the door system and reduces the number of fitting operations. Thanks to the plastic slide rails with zipper, the door is extremely low-maintenance. Suitable as an internal or external door, this variant also offers wind load class 3 and a high degree of tightness. A standard expansive vision field improves safety in day-to-day operation. The upgradable control concept offers additional flexibility in terms of functions.

The side elements have an especially narrow, galvanised steel construction. They are equipped with maintenance-free plastic slide rails for zipper technology, which are supported by a spring-loaded retention system. The side elements are also available with a high-quality colour coating in RAL to choose.

Equipment features

- Zipper technology for curtain stability **1**
- Lateral reinforcing strips
- Galvanized two-piece shaft cover **2**
- Powerful direct drive operator
- High degree of tightness thanks to plastic slide rails for zipper technology
- Automatic re-feed on both sides **3 4 5 6**

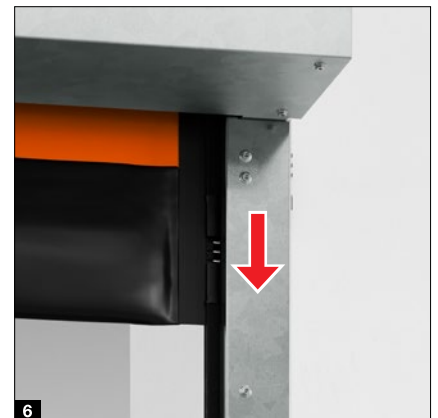
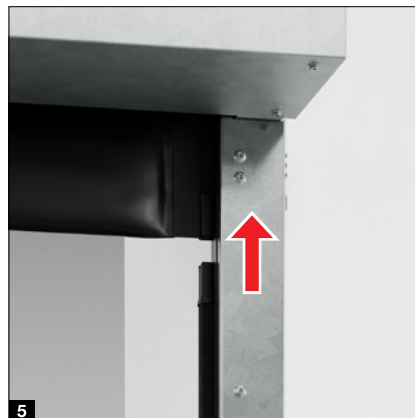

Flexible internal and external doors

Resistant to high wind loads

Door type	V 6030 SEL	V 6020 TRL	V 10008
Suitable application	Interior / exterior	Interior / exterior	Interior / exterior
Size range			
Max. width (mm)	5000	6000	10000
Max. height (mm)	6000	7000	6250
Speed			
Max. opening (m/s)	2.0 / 3.0 ¹⁾	1,0 – 2,0	1.5 (0.8) ⁴⁾
Closing approx. (m/s)	0,8	0,5	0,4
Control			
Standard	BK 150 FUE-1	BK 150 FUE-1 ²⁾ , AK 500 FUE-1 ³⁾	AK 500 FUE-1
Optional	AK 500 FUE-1		
Safety			
Light grille with emergency stop / soft stop function	●	●	–
Contact bar and photocell	–	–	●
Resistance to wind load (EN 12424)			
Door width ≤ 4000 mm	Class 3	Class 2	Class 4
Door width > 4000 mm ≤ 5000 mm	Class 3	Class 2	Class 3
Door width > 5000 mm		Class 2	Class 2
Temperature range	+5°C to +40°C	+5°C to +40°C	+5°C to +40°C
Curtain			
Fabric thickness (mm)	PVC 1,5	PVC 2,4	PVC 1,5
Vision field thickness (mm)	2,0	4,0	2,0
Fully transparent curtain (mm)		4,0	
Fly-protection section	○	–	–
Curtain colours			
Standard colours	●	● ⁵⁾	●
Preferred colours	○	○	○
Wind locks			
Spring steel with side twin rollers and tensioning system	●	●	●
Bottom profile			
SoftEdge	●	–	–
Aluminium	○	●	●
Emergency opening			
Emergency crank handle	●	●	–
Emergency hand chain	○	○	●
Automatic door opening via UPS in case of power failure	○	○	–

● = Standard ○ = Optional

All colours based on RAL

¹⁾ With optional control AK 500 FUE-1

²⁾ Up to 95 kg

³⁾ From 95 kg

⁴⁾ From 6000 mm door width

⁵⁾ Wind lock strips and / or fabric colour (RAL 1018, RAL 3002 only for wind lock strips)

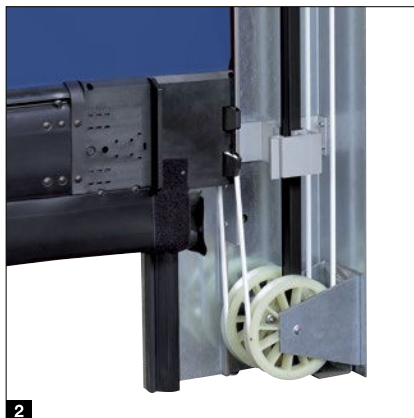
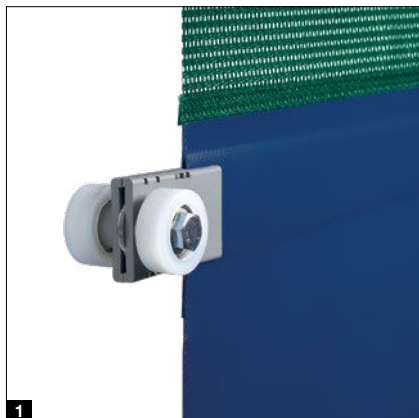

Door type V 6030 SEL – with SoftEdge bottom profile and for high wind loads

When the SoftEdge door is used outside, impact damage in everyday work generally does not have any serious effects. Pull and wind loads do not pose problems thanks to the spring steel wind lock.

Equipment features

- Stabilising spring steel wind lock with optional fly-protection curtain **1**
- Tensioning system for reliable door travel **2**
- Optional aluminium bottom profile **3**

Door type V 6020 TRL – with aluminium bottom profile and transparent curtain

The 4-mm-thick, transparent door curtain allows light to pass through and protects against surprises on transport routes. Optionally, the curtain with coloured fabric material with or without vision field is available. From a door surface of 25 m², we supply the curtain in a coloured fabric material with vision field as standard.

Equipment features

- Transparent curtain for more light and visual contact **4**
- Optional fabric curtain with vision field (also available without vision field) **5**

Door type V 10008 – with aluminium bottom profile for large openings up to 10 m wide

The external door was specifically developed for large openings and high wind loads. Double lashing straps, lateral twin rollers and especially wide side guides ensure safe door travel even with a high door curtain weight. The spring steel wind locks also allow for wind loads of over 100 km/h.

Equipment features

- Stabilising spring steel wind lock **6**



Flexible internal doors with SoftEdge bottom profile

Minimal downtime thanks to the anti-crash function with flexible bottom profile

Door type	V 4020 SEL Alu-R
Suitable application	Interior
Size range	
Max. width (mm)	4000
Max. height (mm)	5000
Speed	
Max. opening (m/s)	2,2
Closing approx. (m/s)	0,8
Control	
Standard	BK 150 FUE-1
Safety	
Light grille with emergency stop / soft stop function	●
Temperature range	+5°C to +40°C
Curtain	PVC
Fabric thickness (mm)	1,5
Vision field thickness (mm)	2,0
Fly-protection section	○
Curtain colours	
Standard colours	●
Preferred colours	○
Wind locks	
Spring steel with side twin rollers	●
Bottom profile	
SoftEdge	●
Aluminium with aluminium profile wind class 3	○
Emergency opening	
Manual door opening using 1/2 inch drive	●
Automatic door opening via UPS in case of power failure	○

● = Standard ○ = Optional

All colours based on RAL

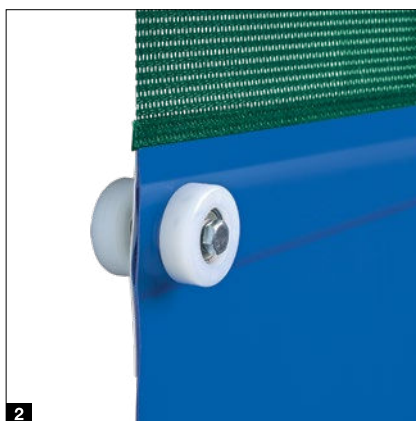
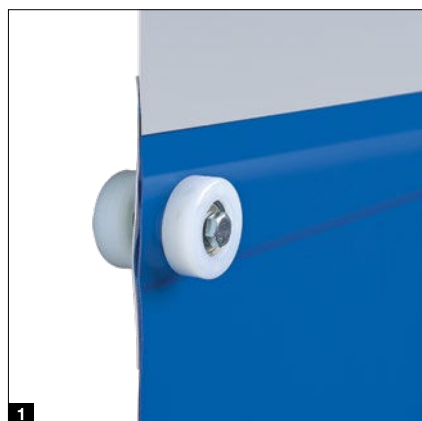

Door type V 4020 SEL Alu-R – for confined areas with customer traffic and light wind loads

The anodised aluminium surface finish of the side elements and top plates, standard shaft cover in White aluminium RAL 9006, integrated wiring and few visible screw fittings lends the door an elegant look and makes it the ideal choice for use in areas with customer traffic. For a high safety level, the door features a light grille as standard which stops the door immediately if a person or vehicle is in the door opening.

The flexible SoftEdge bottom profile prevents downtime due to damage to the door system. You can also optionally obtain the V 4020 SEL Alu-R with aluminium bottom profile for wind class 3 (DIN EN 12424).

The door is fully sealed thanks to the very small gap dimensions of side elements and lip seals. The high-speed door is particularly suitable for narrow fitting situations in high frequency areas thanks to the narrow side elements and the powerful tubular drive.

If the control has to be fitted in the top section due to space limitations, an optional external control panel can be elegantly integrated into the side frame. This allows for the operation of all control functions such as opening and closing as well as service settings. Emergency opening takes place via a 1/2 inch drive. The 10-mm socket (long) is concealed in the top plate.

Equipment features

- Curtain stability thanks to stabilising spring steel wind lock **1**
- Optional fly-protection curtain instead of the vision field **2**
- Shaft cover in White aluminium RAL 9006 **3**
- Powerful with tubular drive for up to 1.5 million door cycles in high use areas **4**
- Convenient operation with the optional external control panel (80 × 120 mm) for integration into the side element at a height of 1300 mm **5**
- High tightness thanks to small gap dimension and lip seals **6**

Optional equipment Clean

- Minimises pressure loss in rooms with differential pressures up to 30 Pa
- Robust aluminium bottom profile
- Additional sealing lip in the cladding
- Inspection openings in the cladding to facilitate door service and maintenance

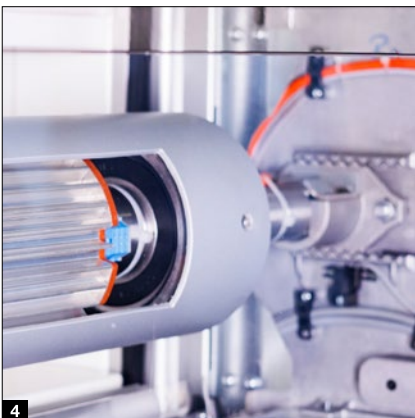

Flexible internal doors with SoftEdge bottom profile

Minimal downtime thanks to the anti-crash function with flexible bottom profile

Door type	V 5015 SEL	V 5030 SEL
Suitable application	Interior	Interior
Size range		
Max. width (mm)	5000	5000
Max. height (mm)	5000	5000
Speed		
Max. opening (m/s)	1,5	2,0
Closing approx. (m/s)	0,8	0,8
Control		
Standard	BK 150 FUE-1	BK 150 FUE-1
Temperature range	+5°C to +40°C	+5°C to +40°C
Curtain	PVC	PVC
Fabric thickness (mm)	1,5	1,5
Vision field thickness (mm)	2,0	2,0
Fly-protection section	○	○
Curtain colours		
Standard colours	●	●
Preferred colours	○	○
Wind locks		
Curtain slides	-	-
Aluminium profiles	●	-
Spring steel with side twin rollers	-	●
Bottom profile		
SoftEdge	●	●
Aluminium for wind load class 1	-	○
Emergency opening		
Emergency crank handle	●	●
Emergency hand chain	○	○
Automatic door opening via UPS in case of power failure	○	○

● = Standard ○ = Optional

All colours based on RAL



Door type V 5015 SEL – for areas without draughts and very easy to service

This internal door comes with safety functions such as SoftEdge and light grille with emergency stop / soft stop function as standard. The aluminium wind lock also makes the door particularly service-friendly, since curtain segments can be quickly replaced if repairs are necessary. For an improved view the curtain is also available with two transparent curtain sections.

Equipment features

- Curtain stability with aluminium profiles **1**
- Optional fly-protection curtain instead of the vision field **2**

Door type V 5030 SEL – for light wind loads and very easy to service

Draughts always pose a particular challenge for doors. With the robust wind locks made of spring steel, the V 5030 SEL remains stable under small pull and wind loads. You can also optionally obtain the V 5030 SEL with aluminium bottom profile for wind class 1 (DIN EN 12424).

Equipment features

- Spring steel wind lock for quiet door travel **3**
- Optional fly-protection curtain instead of the vision field **4**



Flexible internal doors

Ideal for retail and logistics companies and for the food industry

Door type	V 3010
Suitable application	Interior
Size range	
Max. width (mm)	3000
Max. height (mm)	3000
Speed	
Max. opening (m/s)	1,0
Closing approx. (m/s)	1,0
Control	
Standard	AK E 370 M-I
Optional	AK E 370 M, BK 370 M FUE-1
Safety	
Photocell	●
Temperature range	+5°C to +40°C
Curtain	PVC, fibreglass composite material
Fabric thickness (mm)	1,0
Vision field	○
Curtain colours	
Standard colours	●
Preferred colours	○
Side element colours	
Galvanized	●
Standard colours, coated	○
Special colours, coated	○
Stainless steel	○
Bottom profile	
No downtimes resulting from a crash	●

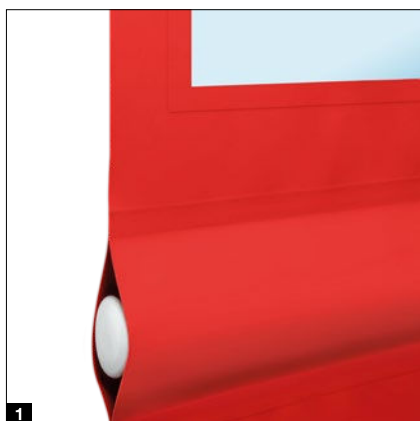

Door type V 3010 – for retail and logistics companies and for the food industry

This inexpensive entry-level door is set apart by a compact construction with integrated control, which allows shelving systems to be placed right up to the door frame. As standard, the door is equipped with barrel and frame covering as well as a motor cover. The drive belt makes the operator especially compact, quiet and maintenance-friendly. A photocell with two light beams ensures reliable function and safety.

Service-friendly integrated control

The entire control, including the control elements, is integrated in the side frame, saving space. During installation and service, the panel can simply be tilted forwards, providing easy access to all the components.

No downtimes resulting from a crash

In the event of a crash, the floor rail of the curtain is forced out of the black PE side guides. The curtain is then automatically reinserted and the door can be operated again.

Easy fitting

The self-supporting construction can also be fitted in tight spaces without any particular structural requirements. In addition, the construction is pre-assembled up to 80%, saving time during fitting.

Equipment features

- 1 × PVC curtain with optional window elements **1**
- Space-saving, integrated control including buttons in the frame **2**
- Service-friendly opening of the integrated control **3**



Individual designs

The V 3010 is available in 5 standard and 6 special colours, as well as with individual printing over the entire surface.

Stainless steel version

For hygienic areas in the food industry, the door is also available in stainless steel and with external control AK E 370 M (IP 65, jet-water protected).

Flexible internal doors

Ideal for retail and logistics companies and for the food industry

Door type	V 4015 Iso L	V 4020 Cold	V 2515 Food L	V 2012
Suitable application	Interior	Interior	Interior	Interior
Size range				
Max. width (mm)	4000	4000	2500	2500
Max. height (mm)	4500	5000	4000	2500
Speed				
Max. opening (m/s)	1,5	2,2	1,2	1,2
Closing approx. (m/s)	0,5	0,8	0,5	0,5
Thermal insulation (EN 13241-1, ISO 12567-1)				
U-value in W/(m ² ·K)	1,6	2,4	-	-
Control				
Standard	BK 150 FUE-1	BK 150 FUE-1	BK 150 FUE-1	BK 150 FUE-1
Temperature range	+1°C to +40°C	Fitting side > 0°C ³⁾ , opposite side max. -28°C ³⁾	+5°C to +40°C	+5°C to +40°C
Curtain	Insulating curtain with a 20 mm PE foam infill	Reflect Curtain in silver	PVC	PVC
Fabric thickness (mm)	-	0,6	1,5	1,5
Vision field thickness (mm)	2.0 ¹⁾	-	2,0	2,0
Fully transparent curtain (mm)	-	-	-	-
Curtain colours				
Standard colours	● ²⁾	-	●	●
Preferred colours	-	-	○	○
ThermoFrame	○	●	-	-
Wind locks				
Aluminium profile	●	-	-	-
Curtain slides	-	●	-	●
Spring steel	-	-	●	-
Bottom profile				
SoftEdge	-	●	●	●
Aluminium	●	-	-	-
Emergency opening				
Emergency crank handle	●	-	-	-
Counter weight with operating current brake	-	-	-	●
Automatic door opening via UPS in case of power failure	○	○	○	-
Manual door opening using 1/2 inch drive	-	●	-	-

● = Standard ○ = Optional

All colours based on RAL

¹⁾ Only one vision field with a height of approx. 230 mm possible per door

²⁾ Only in RAL 7038

³⁾ Deviating temperatures on request

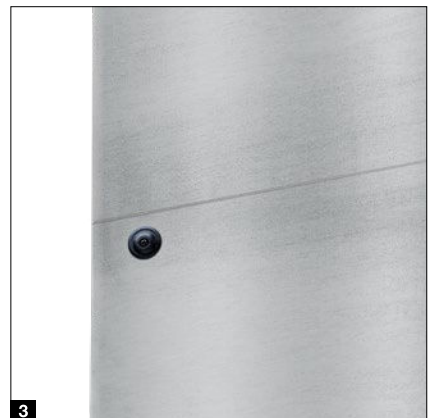
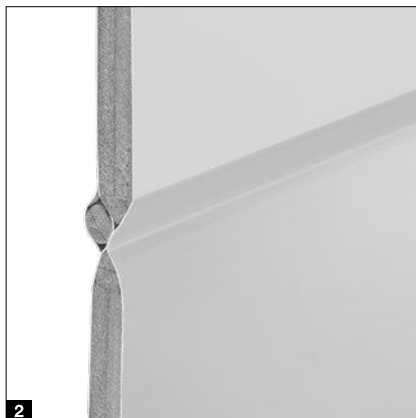
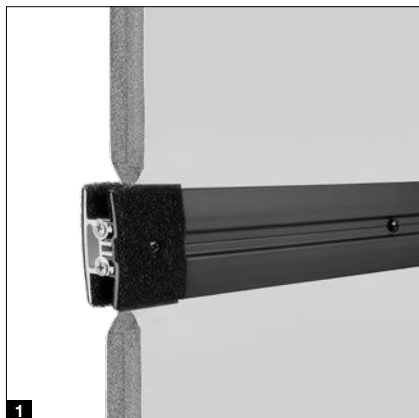

Door type V 4015 Iso L – for use in internal areas in cold store and fresh food logistics (to +5°C)

The door with energy-efficient insulating curtain is the perfect solution for internal areas in cold store and fresh food logistics (to +5°C). The optional ThermoFrame separates the frame from the building structure, thus improving thermal insulation by up to 15%.

Equipment features

- Stabilising wind lock **1**
- PE foam in curtain pockets **2**
- Optional vision field

Door type V 4020 Cold – for internal areas in cold store and deep freeze logistics (to –28°C)

The door with its tubular drive, side elements and control that are heated as standard was specifically developed for interior use in cold store and deep freeze logistics (down to –28°C). The standard ThermoFrame separates the side elements from the building structure and permits a U-value of 2.4 W/(m²·K).

Equipment features

- Reflecting curtain with curtain slide **3**
- SoftEdge bottom profile with manual re-feed
- Safety light curtain
- Integrated wiring in the side elements

Door type V 2515 Food L – for easy cleaning with high-pressure cleaner and water

The side guides of this door, specifically designed for the food industry, are particularly easy to clean. High-pressure cleaning systems and water are not a problem for the door construction, which is made entirely of stainless steel. No counter weights or springs complicate the cleaning of the side elements.

Equipment features

- Standard EPDM seal **4**
- Shaft, side elements and control box made of stainless steel

Door type V 2012 – for retail companies and supermarkets with high customer traffic

Full equipment with operator and shaft cover, light grille in the side elements (monitoring height 350 mm) and automatic emergency opening via a counter weight (in case of power failure) make this flexible plastic curtain door a safe choice for interior uses with a high customer traffic.

Equipment features

- Light grille concealed in the door guide **5**
- Optional custom imprint **6**



Tubular drive with 2.5 million door cycles

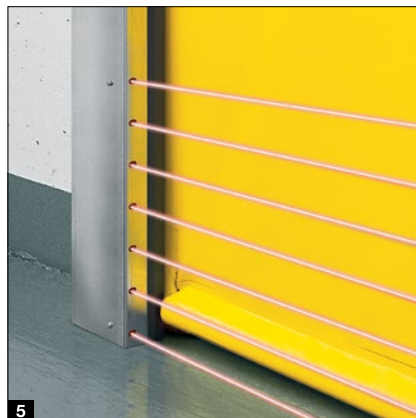

Flexible internal doors

For individual needs in industrial and logistics companies

Door type	V 5030 MSL	V 4020 Protect	V 3009 Conveyor	V 3015 Clean
Suitable application	Interior	Interior	Interior	Interior
Size range				
Max. width (mm)	4000	4000	3500	2500
Max. height (mm)	4000	5000	3500	3000
Speed				
Max. opening (m/s)	1,5	2,2	0.8 (1.2)	1,5
Closing approx. (m/s)	0,8	0,8	0.8 (0.5)	0,5
Control				
Standard	BK 150 FUE-1 ¹⁾ , AK 500 FUE-1 ²⁾	BK 150 FUE-1	AKE	BK 150 FUE-1
Optional	-	AK 500FUE-1	BK 150FUE-1	-
Safety				
Light grille	●	●	-	-
Closing edge safety device, one-way photocell	-	-	●	●
Resistance to wind load (EN 12424)				
Door width ≤ 4000 mm	Class 1	Class 3	-	-
Temperature range	+5°C to +40°C	+5°C to +40°C	+5°C to +40°C	+5°C to +40°C
Curtain				
Fabric thickness (mm)	PVC 2,4	PVC 1,5	PVC 1,5	PVC -
Vision field thickness (mm)	-	2,0	2,0	-
Fully transparent curtain (mm)	4,0	-	-	4,0
Curtain colours				
Standard colours	● ³⁾	●	●	●
Preferred colours	○	○	○	-
Curtain locking strips				
Standard colours	-	-	-	●
Wind locks				
Spring steel	●	●	-	●
Aluminium	-	-	●	-
Bottom profile				
Aluminium	●	●	●	●
Emergency opening				
Emergency crank handle	●	-	●	●
Manual door opening using 1/2 inch drive	-	●	-	-
Automatic door opening via UPS in case of power failure	○	○	○	○
Emergency hand chain	○	-	-	-

● = Standard ○ = Optional

All colours based on RAL

¹⁾ Up to 95 kg

²⁾ From 95 kg

³⁾ Wind lock strips and / or fabric colour (RAL 1018, RAL 3002 only for wind lock strips)



Door type V 5030 MSL – for effective system protection and personal safety with certified safety catch

The requirements for workplace safety and production processes are constantly increasing. Short downtimes, easy and quick access for operation and maintenance of the production machines and of course the safety of the employees are all important for smooth production. Thanks to the safety sensors **1** the door can open only when the machine is idle and the machine can be operated only when the door is closed. The V 5030 MSL with performance level d featuring a fully transparent, 4-mm-thick curtain was developed specifically for this application area. Optionally, the curtain with coloured fabric material is available with vision field.

Door type V 4020 Protect – for effective system protection and personal safety with certified safety catch and small fitting dimensions

For industrial production, fast and smooth processes in compliance with occupational health and safety are a decisive success factor. This requires a separation of machine and system areas on the one hand and work areas with employees on the other. The 1.5 mm thick textile-reinforced curtain and a robust aluminium bottom profile ensure the structural safety of the equipment protection door. The structural stability of the V 4020 Protect was confirmed by a pendulum test in accordance with DIN EN ISO 14120:2015. The safety limit switch sensor **2** integrated in the side element, for example, only enables machine start-ups when the “Bottom end-of-travel position” signal is given. Optionally, this type of switch is also available for the “Top end-of-travel position” signal. Performance level d is achieved here thanks to direct signal evaluation via the system technology.

Door type V 3009 Conveyor – for automated opening and closing processes in conveyor systems with a low lateral space requirement

Due to the low lateral space requirements, this door is specifically designed for integration in conveyor systems and their frequent automated opening and closing cycles. A vision field **3** gives insight into the operating procedure. The operator control can be integrated in existing PLC systems. Two volt-free contacts report the door position (OPEN / CLOSED) to the control.

Door type V 3015 Clean – for clean rooms with differential pressures of up to 50 Pa

Air purification in clean rooms can result in a differential pressure of up to 50 Pa. The fully transparent curtain of the V 3015 Clean is tightly integrated in the special side guides. This minimises air loss (leakage). The operator and shaft cover included as standard provide additional support. The spring steel wind locks fitted in curtain pockets add to the door leaf stability.

Equipment features

- Extremely leaktight and fully transparent **4**
- Curtain tightly integrated in the side guides **5**



High-speed folding doors

Reliable operation for use inside, outside or in deep freeze logistics

Door type	F 6010 / F 6010 Iso	F 4010 Cold
Suitable application	Interior / exterior	Deep freeze area
Size range		
Max. width (mm)	6000	Up to 4000
Max. height (mm)	6000	Up to 5500
Speed		
Max. opening (m/s)	1,0	1,0
Closing approx. (m/s)	1,0	1,0
Control		
Standard	AK E	AK E
Optional	AK 500 FUE-1 ¹⁾ , AK E 2500 M-I	AK 500 FUE-1 ¹⁾ , AK E-750 M
Safety		
Light grille	●	-
Photocell	-	●
Closing edge safety device	○	-
Resistance to wind load (EN 12424)		
Class 4	●	-
Temperature range		
	-5°C to +40°C -30°C to +40°C ²⁾	-30°C to +15°C
Curtain		
Fabric thickness (mm)	PVC, spring steel wind locks 1,0	3 × PVC, fibreglass composite material 1,0
Vision field	○	-
Curtain colours		
Standard colours	●	●
Preferred colours	○	○
Side element colours		
Galvanized	●	●
Standard colours, coated	●	●
Special colours, coated	○	○
Stainless steel	○	○
Side elements		
Flexible guide belts	●	●

● = Standard ○ = Optional

¹⁾ Max. 60 cycles per hour

²⁾ With optional heating in the operator for outside applications



Door type F 6010 – for use outside in areas exposed to very high wind loads

The stable steel wind reinforcement laths are arranged at 600 mm intervals across the entire height of the door. Its standard wind load class 4 ensures reliable operation in outdoor applications.

Equipment features

- 1 × PVC curtain with standard spring steel wind locks and optional window elements **1**
- Flexible guide belts prevent downtime after a crash **4**
- Optional integrated control AK E 2500 M-I **5**

Door type F 6010 Iso* – with good thermal insulation for use outside in areas exposed to very high wind loads

For improved thermal insulation, we recommend the F 6010 Iso with an insulated curtain. With an optional heated operator F 6010 Iso can be used down to -30°C . Its standard wind load class 4 ensures reliable operation in outdoor applications.

Equipment features

- Improved thermal insulation due to the insulated curtain **2**
- Flexible guide belts prevent downtime after a crash **4**
- Optional integrated control AK E 2500 M-I **5**

* Not for use as a deep freeze door

Door type F 4010 Cold – for all indoor areas in deep freeze logistics (to -30°C)

The flexible high-speed folding door F 4010 Cold is the optimal solution for all interior uses in deep freeze logistics. The triple-insulated curtain reliably reduces cooling losses in deep freeze areas and the opening speed of 1 m/s ensures the rapid flow of traffic for maintaining the cold chain.

Equipment features

- 3 × insulated curtain for reducing cooling losses **3**
- Flexible guide belts prevent downtime after a crash **4**
- Heated frames for use in deep freeze areas with temperatures down to -30°C **6**

Note:

Useful optional extras provided on site, such as underfloor heating, air curtain systems or dehumidifiers, ensure the reliable function of the high-speed folding doors.

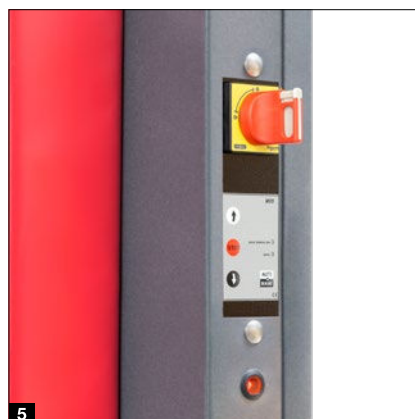

High-speed folding doors

For large openings and reliable operation for indoor and outdoor areas

Door type	F 8005	F 14005
Suitable application	Interior / exterior	Interior / exterior
Size range		
Max. width (mm)	8000	14000
Max. height (mm)	10000	8500
Speed		
Max. opening (m/s)	0,5	0,5
Closing approx. (m/s)	0,5	0,5
Control		
Standard	AK E-700 M	AK E-700 M
Optional	-	-
Safety		
Light grille	-	-
Photocell	●	-
Closing edge safety device	-	●
Resistance to wind load (EN 12424)		
Class 2 ²⁾	●	●
Class 3 ²⁾	●	●
Class 4 ²⁾	●	●
Temperature range	-5°C to +40°C	-5°C to +40°C
Curtain	PVC, spring steel wind locks	PVC, spring steel wind locks
Fabric thickness (mm)	1,0	1,0
Vision field	○	○
Curtain colours		
Standard colours	●	●
Preferred colours	○	○
Side element colours		
Galvanized	-	-
Standard colours, coated	●	●
Special colours, coated	○	○
Stainless steel	-	-
Side elements		
Flexible guide belts	-	-

● = Standard ○ = Optional

All colours based on RAL

¹⁾ Max. 60 cycles per hour
²⁾ Dependent on door size

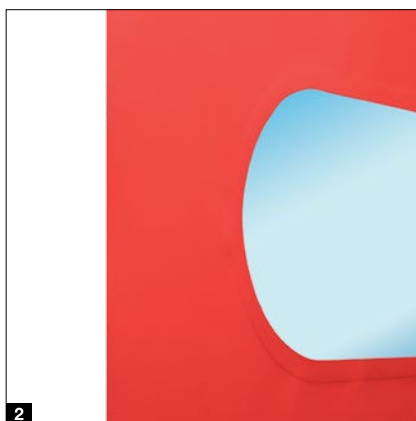
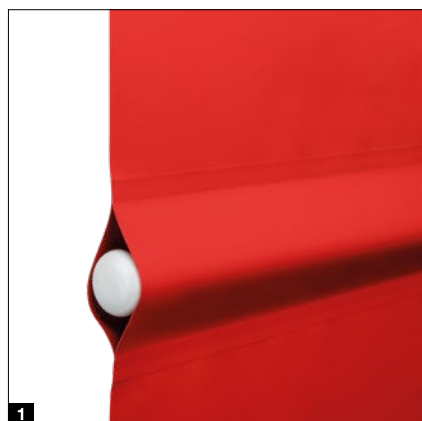

Door type F 8005 – for large openings up to 8 m wide and for use outside in areas exposed to very high wind loads

For openings up to 8 m wide and 10 m high, we recommend high-speed folding door F 8005 with robust steel wind reinforcement laths and two operators connected in parallel.

Equipment features

- 1 × PVC curtain with standard spring steel wind locks **1**
- Optional window elements **2**

Door type F 14005 – for very large openings up to 14 m wide and for use outside in areas exposed to very high wind loads

The high-speed folding door reduces energy loss and draughts at large external door openings up to 14 m wide and 8.5 m high. Up to a width of 10 m, the doors reliably withstand wind loads up to class 4 as standard. The door is equipped with two operators working in parallel.

Equipment features

- 1 × PVC curtain with standard spring steel wind locks **1**
- Optional window elements **2**

Individual colour schemes

For greater design freedom

Standard colours

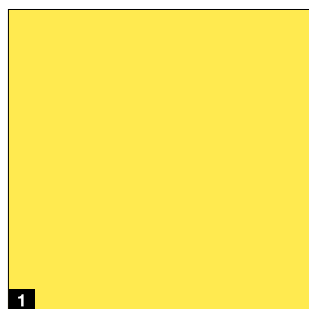

1



4

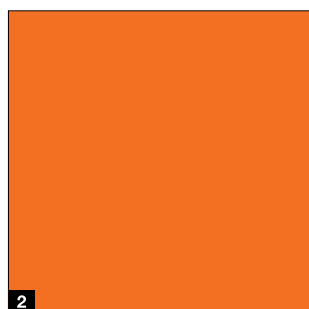

2

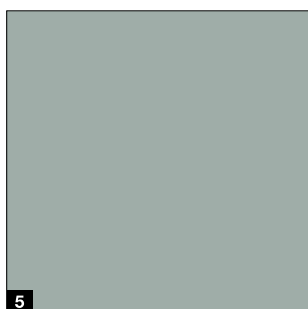

5

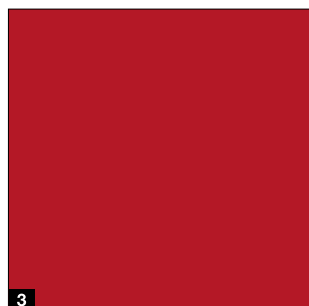

3

Standard colours

- 1 RAL 1018 Zinc yellow
- 2 RAL 2004 Pure orange
- 3 RAL 3002 Carmine red
- 4 RAL 5010 Gentian blue
- 5 RAL 7038 Agate grey

Door types

All high-speed doors (curtain)
All high-speed folding doors (curtain and side elements)

Preferred colours

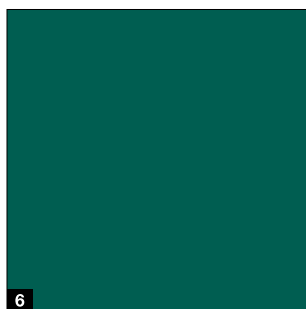

6

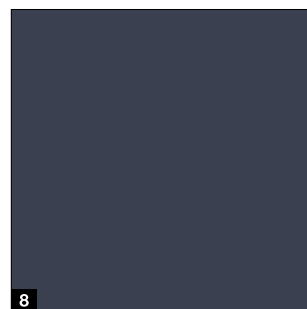

8

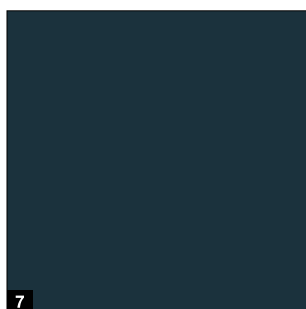

7



9

Preferred colours

- 6 RAL 6026 Opal green
- 7 RAL 7016 Anthracite grey
- 8 RAL 7024 Graphite grey
- 9 RAL 9005 Jet black

Door types

All high-speed doors (curtain) except V 3010,
V 4020 Cold, V 5030 MSL, V 6020 TRL

Note

The colours shown are subject to the limitations of the printing process and cannot be regarded as binding. All colours based on RAL.

Please consult with your Hörmann sales partner.

Stainless steel

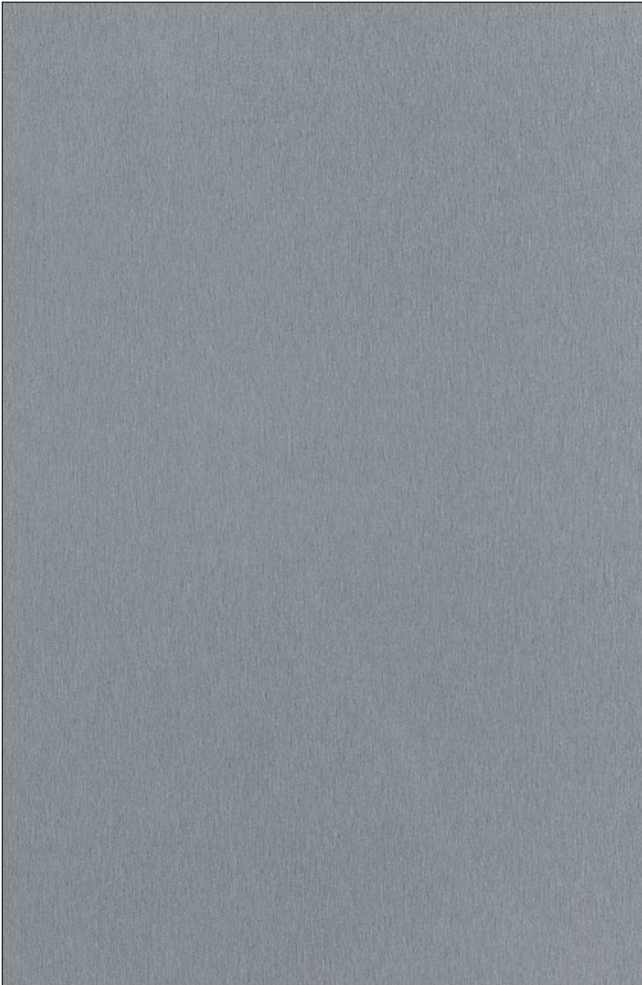

Polished finish, K240

This surface is ground first and then brushed to refine and finish it.

Door types

Standard for flexible high-speed doors V 3015 Clean and V 2515 Food L:
Side elements, control box, shaft and operator covers

Optional for all other flexible high-speed doors*: Side elements, shaft and operator covers

Optional for high-speed folding doors F 6010 / F 6010 Iso, F 4010 Cold:
Side elements

* (except V 4020 SEL Alu-R, V 4020 Cold, V 4020 Protect, V 10008)

Intelligent operator and control technology

Standard at Hörmann



Reliable thanks to innovative equipment*

Hörmann high-speed doors are up to 20 times faster than conventional industrial doors, which is why the intelligent operator and control technology is designed for reliable continuous operation.

Frequency converter control

High performance frequency converter controls (FU) feature higher speeds and relieve the complete door mechanism which, in turn, extends the service life of the door considerably.

Advantages at a glance

- Door cycle counter
- Operation time monitoring
- Automatic timer (adjustable hold-open phase)
- Error display / diagnosis via a 4 x 7-segment display
- Service operation setting
- Colour-coded plug-in control wiring

* Dependent on door version

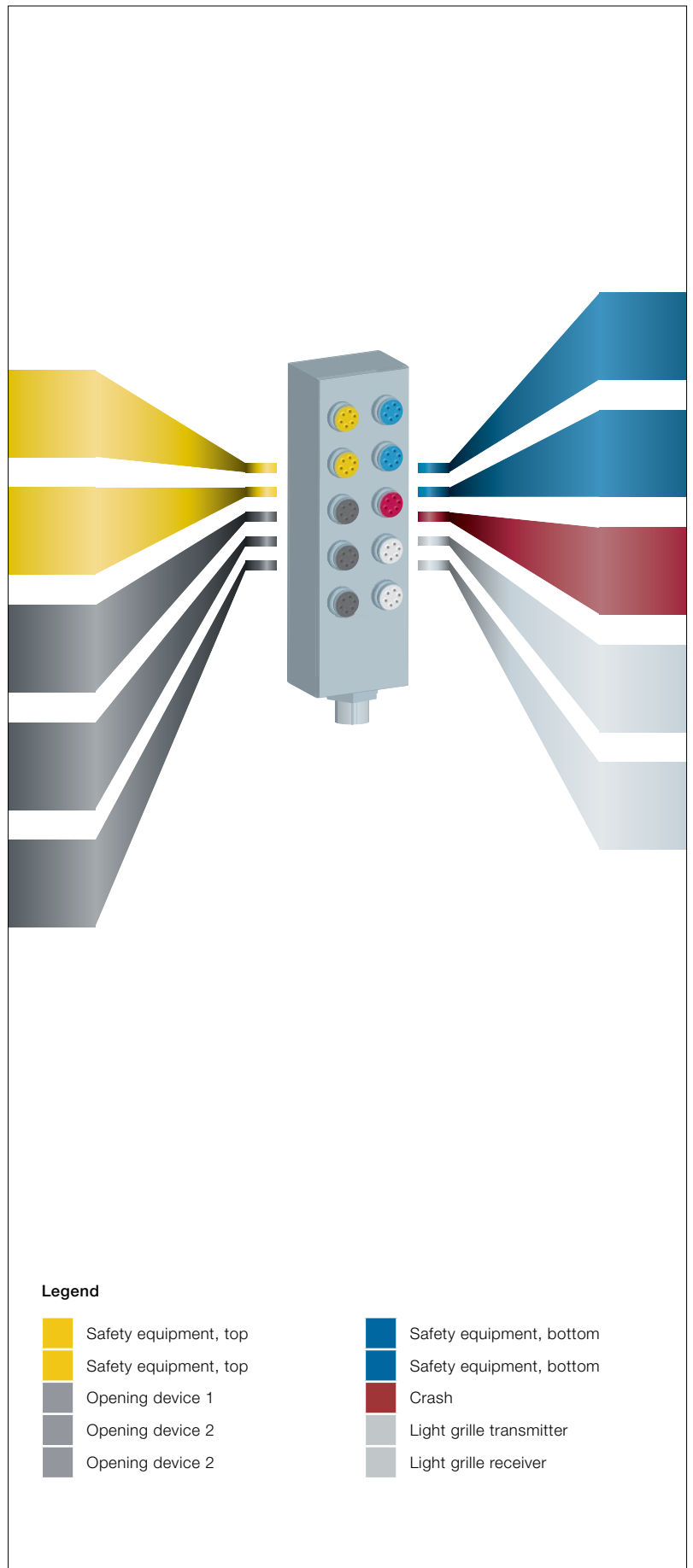

Controls

For spiral doors and high-speed sectional doors, flexible high-speed doors and high-speed folding doors



Controls	BK 150 FUE-1	AK 500 FUE-1	BK FU Z	AK E	AK
Frequency converter control	●	●	●		
Inversion relay control				●	●
Housing					
Plastic housing	●	●	●	●	●
Steel housing	○	○		○	
Stainless steel housing	○	○		○	
Operation					
Open / Stop / Close membrane push button	●	●	●	●	●
Lockable main switch	○	●	○ ¹⁾	○ ¹⁾	○ ¹⁾
Emergency-off button	○	●	●	●	●
Display, 4x, 7 segments	●	●	●	●	●
Functions					
Automatic timer	●	●	●	●	●
Adjustable hold-open phase	●	●	●	●	●
Safety light curtain	●	●	●		●
Safety photocell				● ⁴⁾	
Closing edge safety device	● ²⁾	● ³⁾		●	
Stop/re-open	●	●	●	●	●
Extension options					
Traffic light	○	○	○	○	○
Flashing warning light	○	○	○	○	○
Locking	○	○		○	
Intermediate stop	○	○		○	
Extension PCB	○	○		○	
Protection category	IP 65	IP 65	IP 54	IP 54	IP 54
Power supply					
Connecting lead 1~230 V, PE, 16 A, slow-acting	●		●		
Connecting lead 3~400 V, PE, 10 A, slow-acting				●	●
Connecting lead 3~400 V, PE, 16 A, slow-acting		●			
Cable set for plug-in connection between door operator and control cabinet ⁵⁾	6.5 m	6.5 m	6.5 m	6.5 m	6.5 m
Cable for on-site CEE socket	0.8 m, 230 V, blue	0.8 m, 400 V, red	0.8 m, 230 V, blue	1 m, 400 V, red	1 m, 400 V, red
Housing dimensions (without wall holder)	230 x 460 x 200	230 x 460 x 200	180 x 320 x 100	180 x 320 x 100	180 x 320 x 100

● = As standard ○ = Optional

¹⁾ Main switch only optionally available as surface-mounted version

²⁾ For V 3015 Clean

³⁾ For V 10008

⁴⁾ Only for F 6010, F 6010 ISO, F 4010 Cold

⁵⁾ Different cable lengths optionally available on request



Controls	AK E 2500 M-I	AK E 700xM	AK E 750 M	AK E 370 M-I	AK E 370 M	BK 370 M FUE-1
Inversion relay control	●	●	●	●	●	●
Housing						
Plastic housing		●	●		●	●
Integrated (frame)	●			●		
Operation						
Open / Stop / Close membrane push button	●	●	●	●	●	●
Main switch	●	●	●	●	●	●
Emergency-off button	●	●	●	●	●	●
Display	●	●	●	●	●	●
Functions						
Electronic end-of-travel position setting	●			●		
Automatic timer	●	●	●	●	●	●
Adjustable hold-open phase		●	●		●	●
Safety photocell		●	●		●	●
Stop/re-open		●	●		●	●
Extension options						
Traffic light	●	●	●	●	●	●
Flashing warning light	●	●	●	●	●	●
Locking	●	●	●	●	●	●
Intermediate stop	●	●	●	●	●	●
Protection category	IP 20	IP 65	IP 65	IP 20	IP 65	IP 65
Power supply						
Connecting lead 3~400 V, PE, 10 A, slow-acting	●	●	●	●	●	●
Connecting lead 3~230 V, PE, 25 A, slow-acting	●	●	●	●	●	●
Cable set for plug-in connection between door operator and control cabinet	6.5 m, 5-pin, CEE plug			6.5 m, 5-pin, CEE plug		
Cable for on-site CEE socket	1 m, 16 A			1 m, 16 A		
Housing dimensions		400 x 500 x 200	355 x 400 x 200		380 x 290 x 150	400 x 400 x 170

● = As standard ○ = With corresponding equipment, possibly with additional control

**Extension PCB for controls
BK 150 FUE-1, AK 500 FUE-1**



Expansion card with 6 relays

Air lock control, 6 additional switching outputs (1 x 4, 2 x 1 volt-free), 6 additional digital inputs

Expansion card with 1 relay

Air lock control, 1 additional switching output



Induction loop evaluation unit

1- or 2-channel plug-in print suitable for 2 separate induction loops, supplied without loop cable

**Plain text display for controls
BK 150 FUE-1 and AK 500 FUE-1**



Plug-in module, plain text display of settings and states, language selection DE / EN / SP / FR, facilitates readout and programming of the operator control

Accessories

For controls BK 150 FUE-1, AK 500xFUE-1, AK E and AK Exlight



HS 4 BS
4 button functions,
textured surface matt black



Industrial hand transmitters HSI 3xBS, HSI 6xBS, HSI 15 BS
For controlling up to 3 doors (HSI 3xBS), 6 doors (HSI 6 BS) or 15 doors (HSI 15 BS), with extra-large buttons for easier operation with work gloves, impact-resistant housing, protection category: IP 65



External control element for FUE-1
For easy operation and programming,
can be placed independent of the control,
same control buttons as on the control,
4 x 7-segment display



1-channel relay receiver HER 1 BS
1 volt-free relay output with status query



2-channel relay receiver HET-E2 24 BS
2 volt-free relay outputs for choosing the
direction, one 2-pin input for volt-free
OPEN / CLOSE limit switch reporting
(for querying the door position)



Only from Hörmann

Modern radio system

The bi-directional BiSecur radio system is based on future-oriented technology for the convenient and secure operation of industrial doors. The extremely secure BiSecur encryption protocol makes sure that no-one can copy your radio signal. It was tested and certified by security experts at Bochum university.

Your advantages

- 128-bit encryption with the same high security level as online banking
- Interference-resistant radio signal with a stable range
- Convenient querying of the door position*
- Backwards compatible, i.e. radio receivers with the frequency 868 MHz (2005 to June 2012) can also be operated with BiSecur control elements

* For WA 300 S4 with optional bi-directional receiver ESEi BS, for all other operators with optional bi-directional receiver HET-E2 24 BS and end-of-travel position feedback



**Radar movement detector
MWD-C**

Fast and targeted automatic door opening, directional recognition, max. fitting height 7 m, fitting in deep freeze area possible to max. -22°C, IP 65



Pull switch with plastic pull cord

Horizontal or vertical fitting possible, aluminium die-cast housing, IP 65, cord length 4 m



Wireless opening devices

With radio mushroom button, radio and batteryless transmitter, black plastic, IP 66



Push button

2 × "OPEN / CLOSE" or 3 × "Open / Emergency-off / Close", plastic housing, IP 65



Mushroom button

With large operating surface, plastic housing, IP 65



Radar button HTR 1-24

Sensor for non-contact opening, plastic housing, IP 41



Non-contact opening sensor

Plastic housing, IP 65



Warning light Ø 150 mm

Red, plastic housing with mounting strap, IP 65



Warning light Ø 150 mm

Red, green, plastic housing with fitting support, IP 65



Multi-function light

Red or yellow, plastic housing, IP 54



Flashing warning light

Orange, plastic housing, IP 65



LED traffic light strip

24 V DC, RGB, length 2000 mm, IP 44

Accessories

For controls BK 150 FUE-1, AK 500 FUE-1



3D laser scanner Scanprotect

Thanks to laser technology, the high-end motion detector and monitoring system guarantees operational safety, even with different floor coverings. The laser field acts as a reliable door monitor. It detects how fast and in which direction the object is travelling, ensuring optimum opening and closing response times. This minimises a door's hold time and saves energy.

- Especially suited for outdoor areas as it is not susceptible to adverse weather conditions **1**
- Reliable advance protection, as well as fast and targeted automatic door opening
- Eco-Open function for energy savings thanks to automatic opening height adjustment depending on the detected vehicle height in the detection zone **2**
- Minimises the hold time of the door to save energy **3**
- Convenient setting options via the operator control
- Easy to hide objects permanently or temporarily in the detection range **4**
- Deactivation of cross-traffic and pedestrian traffic **5**
- Virtual pull switch enables door opening by people or vehicles standing at a defined position
- Visible LED spots on the floor assist during setup
- Easy connection to the operator control with plug-in wiring
- Bluetooth module for convenient configuration via app, e.g. with visualisation of the set field sizes in real-time
- For use in a temperature range down to -30°C

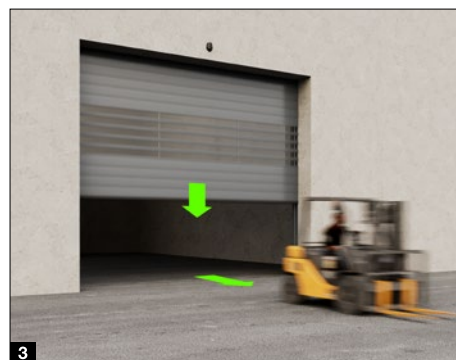
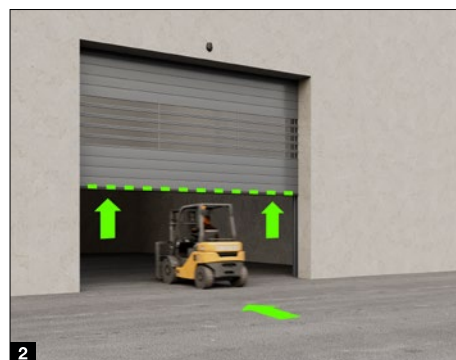

Accessories

For controls

AK E 700 M, AK E 2500 M-I, AK E 750 M, AK E 370 M-I, AK E 370 M, BK 370 M FUE-1



4-button hand transmitter
Black



Pull switch with cord
Horizontal or vertical fitting possible, aluminium die-cast housing IP 65, cord length 4 m



Radio receiver
For control via hand transmitter



Push button
3 x "Open / Emergency-off / Close", plastic housing, IP 65



Push button
2 x "OPEN / CLOSE", plastic housing, IP 65



Mushroom button
With large operating surface, plastic housing, IP 65



Induction loop
Induction loop detector with normally open contact and change-over contact, can be set to pulse or permanent contact, direction recognition, 50 m loop cable



Radar sensor
Fast and targeted automatic door opening, directional recognition, IP 65



Rotating warning light
Red or yellow, plastic housing, IP 54

Hörmann. For Life.

Thanks to their superior quality, Hörmann products ensure that residential and industrial buildings as well as construction projects function sustainably, reliably and economically. They are a crucial part of your building – and will remain so over the long term.

**INDUSTRIAL DOORS. LOADING TECHNOLOGY.
SLIDING DOORS. CONSTRUCTION PROJECT
DOORS. PERIMETER PROTECTION SYSTEMS.**



Some of the products shown feature special equipment and do not always correspond to the standard versions. The surface finishes and colours shown are subject to the limitations of the printing process and cannot be regarded as binding. All RAL colours are based on the RAL colour chart. All rights reserved. No part may be reproduced without our prior permission. Subject to changes.

HÖRMANN