



DOUBLE AND COLLECTIVE GARAGE DOORS

NEW. Non-protruding up-and-over door ET 500 Series 3, non-protruding up-and-over door ET 450

HÖRMANN



4



14



18



Content

4 Good reasons to try Hörmann

14 Inspirations

14 **NEW.** Non-protruding up-and-over door ET 500 Series 3

15 Sliding door ST 500

16 **NEW.** Non-protruding up-and-over door ET 450

17 Up-and-over door N 500

18 Versions, accessories, technology

20 Design overview

22 Door leaf versions

23 **NEW.** TRESPA® decor infills

24 **NEW.** Perforated mesh, expanded mesh infills

24 Colours

26 Up-and-over door N 500

28 **NEW.** Non-protruding up-and-over door ET 450

30 **NEW.** Non-protruding up-and-over door ET 500 Series 3

32 Sliding door ST 500

34 Side doors and wicket doors

36 Operators

38 Accessories

40 Dimensions and technical manual

IMAGE PAGE 2. Non-protruding up-and-over door ET 500 Series 3, style 405 with on-site cladding

Brand quality made in Germany



The family-owned company Hörmann offers all important construction components for building and renovating projects from a single source. We manufacture in highly specialised factories using state-of-the-art production technologies. Our employees work intensively on new products, continual further developments and improvements to details. The results are patents and unique products on the market.



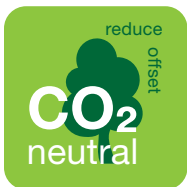

WE THINK AND ACT GREEN. As a family business, we are very conscious of our responsibility to future generations and will offer all products for construction projects as CO₂-neutral versions upon customer request. In this way, customers have the option to offset remaining emissions and make a contribution to climate protection when purchasing our products. The Hörmann sustainability strategy aims to reduce and avoid emissions. We cover 100% of our electrical power needs at all European production sites with genuine green electricity from renewable sources. We also apply many other measures to reduce our consumption and save more than 75000 tonnes of CO₂ each year. We work with ClimatePartner to offset the remaining emissions by supporting certified climate protection projects.



You can find further information at www.hoermann.com/sustainability



ClimatePartner
certified product
climate-id.com/FYZNUF



CO₂
measure
reduce
contribute

Sustainable planning for trend-setting construction

Experienced specialists within our customer-oriented sales organisation accompany you from the planning stage, through technical clarification up to the final building inspection. Complete working documentation, such as technical manuals, is always accessible and up-to-date at www.hoermann.com/en/





SUSTAINABILITY DOCUMENTED. Hörmann has already received confirmation of sustainability through an Environmental Product Declaration (EPD) in accordance with ISO 14025 from the Institut für Fenstertechnik (ift – Institute of window technology) in Rosenheim, Germany. This EPD was created based on EN ISO 14025:2011 and EN 15804:2012 + A1:2013. In addition, the general guidelines for the preparation of type III Environmental Product Declaration apply. The declaration is based on PCR documents “PCR Part A” PCR-A-0.3.2018 and “Doors” PCR-TT-2.2:2018.



PRODUCT PORTAL FOR ARCHITECTS AND PLANNERS.

Clearly structured navigation and a search function provide faster access to texts for invitations to tender, technical data, certificates, CAD drawings and much more. In addition, BIM data can be provided for many products for the Building Information Modelling process, enabling efficient planning, drafting, construction and management of buildings. Photos and photo-realistic presentations provide additional information on many products.



We are a member of the professional association for digital building products in the Federal Association of Building Systems e.V.



Smooth, quiet door travel even at high frequencies

Twin rollers in the guide rail and guide rollers with ball-bearings allow the door to operate smoothly, quietly and precisely – even in continuous use. The non-protruding up-and-over doors ET 450 and ET 500 Series 3 and the sliding door ST 500 are designed for a service life of at least 250,000 door cycles; the up-and-over door N 500 with an optional reinforced spring assembly for approximately 100,000 door cycles.





Tested and certified

APPROVED DOOR AND OPERATOR

UNIT. All double and collective garage doors are always tested and certified by independent, recognised institutes together with their corresponding operators. This ensures that the door and operator unit run smoothly and securely, which is especially important when fitting the door in public areas, such as underground and collective garages. This is especially important when fitting the door in public areas, such as underground and collective garages. The wear-free counter weight technology of the non-protruding up-and-over doors ET 450 and ET 500 Series 3 ensures that the door opens and closes quietly and safely.



ALL-ROUND WELL SECURED. The open design with safety clearance between the door leaf and building structure offers reliable protection against finger injuries on the side and bottom edges. A special EPDM profile shape protects the closing edge of the door leaf. For sliding door ST 500, an integrated photocell also secures the door opening. The non-protruding up-and-over doors ET 450 and ET 500 Series 3 have an additional second photocell (pre-assembled at the factory). **1**



PRACTICAL WICKET DOORS AND SIDE

DOORS. On request, double and collective garage doors are also available with a practical wicket door* or with a side door matching the design. The wicket door is positioned centrally. An integrated overhead door closer **2** and concealed hinges **3** are part of the standard scope of delivery.

* Not available for ET 450

Innovative operator technology

Hörmann operators offer more convenience, smart functions and intelligent technology. The automatic safety cut-out and the safety edge stop the door securely and reliably if it encounters an obstacle. Your door opens and closes quietly and smoothly with the soft start and soft stop.





Soft start
Soft stop



Opening speed
up to 0.5 m/s

QUICK DOOR OPENING. The operator SupraMatic is available in three versions depending on requirements and features an opening speed of up to 0.22 m/s and smart additional functions. With the operator ITO 500 FU, developed specifically for collective garages, you can open the non-protruding up-and-over doors ET 500 and sliding doors ST 500 particularly quickly with an opening speed of up to 0.5 m/s.

→ For further information, see from page 36.



Easy to fit and
service



Hörmann BlueControl app
For operator ITO 500 FU and control 560

SERVICE-FRIENDLY. Initial start-up, service and maintenance of doors with operator ITO 500 FU is easy and convenient with the new BlueControl app.

→ Available for non-protruding up-and-over doors ET 500 and sliding doors ST 500 with operator ITO 500 FU and control unit 560.

The **Hörmann BlueControl app** enables smart set-up and adjustment of the operator control.



IMAGE PAGE 10: Non-protruding up-and-over door ET 500 Series 3, style 413, Anthracite grey RAL 7016

Intelligent operating comfort

Hörmann offers you a comprehensive range of accessories from hand transmitters and control elements to posts and warning light systems. This allows you to control your door operators easily, safely and conveniently. All operators, receivers and control elements with BiSecur radio technology are 100% compatible with each other.





Only from Hörmann

CERTIFIED SAFETY. The bidirectional BiSecur radio system with particularly secure encryption protocol and stable, interference-free range makes sure that no one can copy your radio signal. This is also confirmed by the security experts of Bochum University and independent test institutes.

→ For further information, see from page 36.

SPECIFICALLY FOR COLLECTIVE GARAGES. With the optional collective garage receiver and the easy-to-use software, you can conveniently and clearly manage up to 1000 hand transmitters. Using the respective hand transmitter programming device, the 868 MHz fixed codes* of the hand transmitters can be read in and assigned to individual flats, and the radio codes transferred to the collective garage receiver via a memory card.

* No BiSecur radio

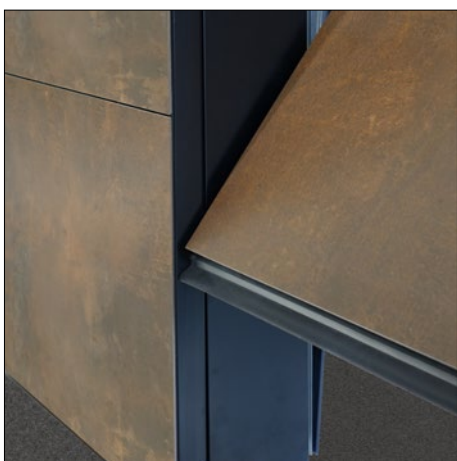

NEW. NON-PROTRUDING UP-AND-OVER DOOR ET 500 SERIES 3.

The non-protruding up-and-over door ET 500 Series 3 does not swivel out during opening and closing, and so the area in front of the door can be taken full advantage of. It is therefore optimal for collective garages opening onto pavements, for example. An additional second photocell ensures a particularly high level of safety for personal protection. The ET 500 Series 3 is also available with a wicket door.

→ For further information, see from page 30.



SLIDING DOOR ST 500. The design of the sliding door ST 500 features a low fitting depth in the lintel area.

→ For further information, see from page 32.

TOP LEFT. Non-protruding up-and-over door ET 500 Series 3, style 413 Anthracite grey RAL 7016

BOTTOM RIGHT. Sliding door ST 500, style 412 Anthracite grey RAL 7016





NEW. TOP LEFT. Up-and-over door ET 450, style 470

BOTTOM RIGHT. Up-and-over door N 500, style 405, with on-site cladding, installed flush-fitting

NEW. NON-PROTRUDING UP-AND-OVER DOOR ET 450. The non-protruding up-and-over door ET 450 is extremely cost-effective and is ideal for collective garages. An additional second photocell provides increased personal protection.

→ For further information, see from page 28.



UP-AND-OVER DOOR N 500. The up-and-over door N 500 with a width of up to 5500 mm is suited for double garages in private areas and for collective garages with up to 100 parking spaces.

→ For further information, see from page 26.

INDIVIDUAL DESIGNS. All door types offer a wide variety of styles, preferred colours as well as on-site design options.

→ For further information, see from page 20.





20

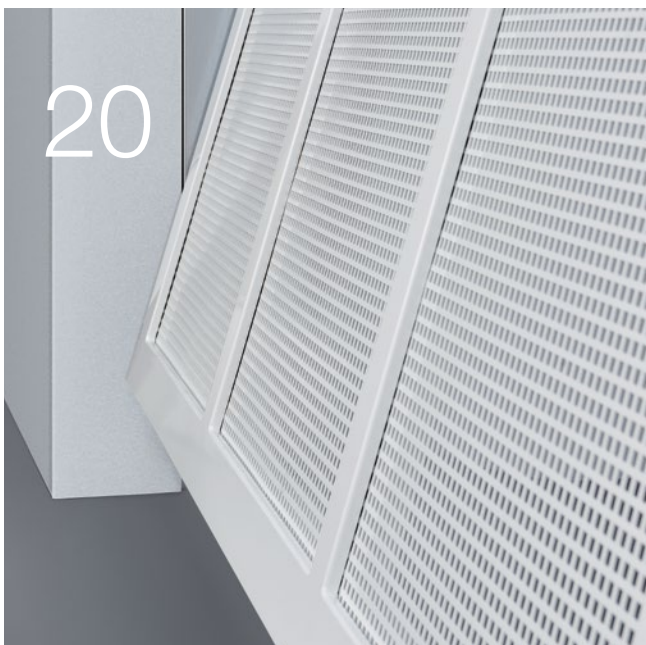

23



36



Design Equipment Accessories

- 20 Design overview
- 22 Door leaf versions
- 23 **NEW.** TRESPA® decor infills
- 24 **NEW.** Perforated mesh,
expanded mesh infills
- 24 Colours
- 26 Up-and-over door N 500
- 28 **NEW.** Non-protruding up-and-over
door ET 450
- 30 **NEW.** Non-protruding up-and-over
door ET 500 Series 3
- 32 Sliding door ST 500
- 34 Side doors and wicket doors
- 36 Operators
- 38 Accessories
- 40 Dimensions and technical manual

IMAGE PAGE 18. Up-and-over door N 500,
style 400, with on-site cladding

Steel doors

Overview

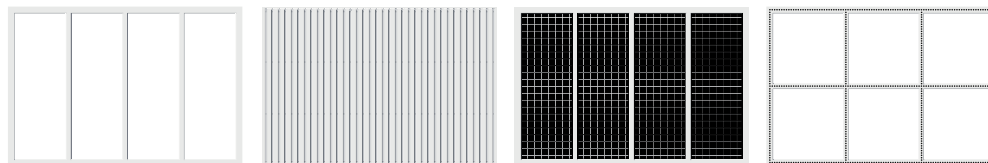

Style	400	402	403	405
Up-and-over door N 500				
Colour	Traffic white RAL 9016 7 preferred colours RAL to choose	Traffic white RAL 9016 7 preferred colours RAL to choose	Traffic white RAL 9016 7 preferred colours RAL to choose	Terra brown RAL 8028 7 preferred colours RAL to choose
Max. width (mm)	5500	5500	5500	5500
Max. height (mm)	2750	2750	2750	2750

Non-protruding up-and-over door ET 500 / sliding door ST 500

Colour	White aluminium RAL 9006 16 preferred colours RAL to choose	White aluminium RAL 9006 16 preferred colours RAL to choose	White aluminium RAL 9006 16 preferred colours RAL to choose	White aluminium RAL 9006 16 preferred colours RAL to choose
Max. width (mm)	6000	6000	6000	6000 ²⁾
Max. height (mm)	3000	3000	3000	3000

NEW. Non-protruding up-and-over door ET 450

Colour		Traffic white RAL 9016 16 preferred colours RAL to choose		
Max. width (mm)		4500		
Max. height (mm)		2500		

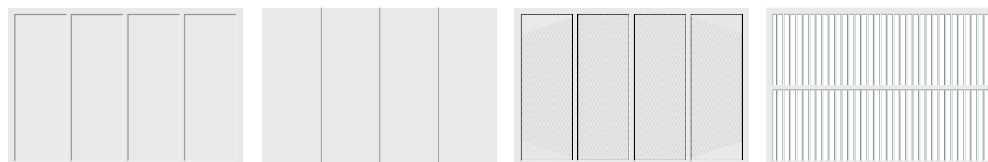

Style	420	422	440	470
Up-and-over door N 500				
Colour	Traffic white RAL 9016 7 preferred colours RAL to choose	Traffic white RAL 9016 7 preferred colours RAL to choose	Traffic white RAL 9016 7 preferred colours RAL to choose	
Max. width (mm)	5500	5500	5500	
Max. height (mm)	2750	2750	2750	

Non-protruding up-and-over door ET 500 / sliding door ST 500

Colour	White aluminium RAL 9006 16 preferred colours RAL to choose	White aluminium RAL 9006 16 preferred colours RAL to choose	White aluminium RAL 9006 16 preferred colours RAL to choose	White aluminium RAL 9006 16 preferred colours RAL to choose
Max. width (mm)	6000 ¹⁾	6000 ¹⁾	6000 ¹⁾	6000
Max. height (mm)	3000	3000	3000	3000

NEW. Non-protruding up-and-over door ET 450

Colour	Traffic white RAL 9016			Traffic white RAL 9016 16 preferred colours RAL to choose
Max. width (mm)	4500			4500
Max. height (mm)	2500			2500

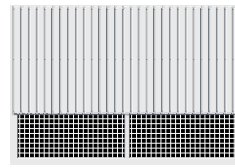
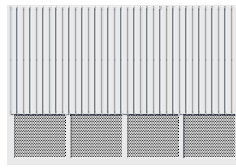
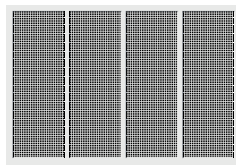
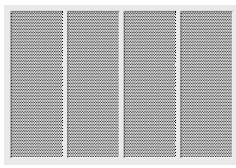

412 / 432⁵⁾

413 / 433⁵⁾

414

NEW. 416

Traffic white RAL 9016
7 preferred colours
RAL to choose

Traffic white RAL 9016
7 preferred colours
RAL to choose

5500
2750

5500
2750

White aluminium RAL 9006
16 preferred colours
RAL to choose

White aluminium RAL 9006
16 preferred colours
RAL to choose

White aluminium RAL 9006
16 preferred colours
RAL to choose

6000
3000

6000
3000

6000
3000

Traffic white RAL 9016
16 preferred colours
RAL to choose

Traffic white RAL 9016
16 preferred colours
RAL to choose

4500
2500

4500
2500

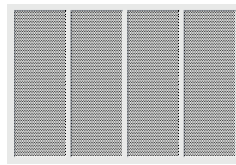
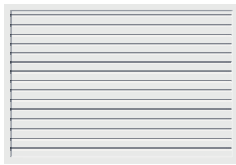

480⁷⁾

NEW. 497⁶⁾

NEW. 498⁶⁾

499

White aluminium RAL 9006
16 preferred colours
RAL to choose

White aluminium RAL 9006
16 preferred colours
RAL to choose

White aluminium RAL 9006
16 preferred colours
RAL to choose

Individual designs

5500²⁾
3000

4750³⁾
3000

6000⁴⁾
3000

6000
3000

¹⁾ Door width with wicket door max. 5500 mm
²⁾ Door width with wicket door max. 5000 mm
³⁾ Door width with wicket door max. 3750 mm
⁴⁾ Door width with wicket door max. 6000 mm

⁵⁾ Style 432, 433 only available for ET 500 / ST 500
⁶⁾ Style 497, 498 available for ET 500-3 and ST 500
⁷⁾ Door width style 480 with wicket door:
ET 500 max. 4750 mm; ST 500 max. 5000 mm

Steel doors

Door leaf versionsw

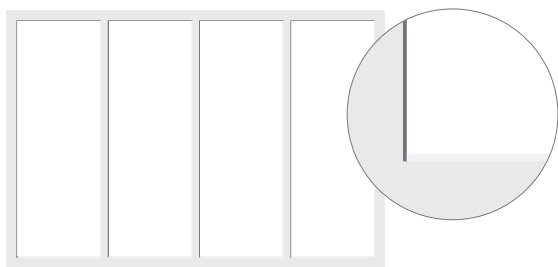

Style 400
Frames for internal, on-site infill

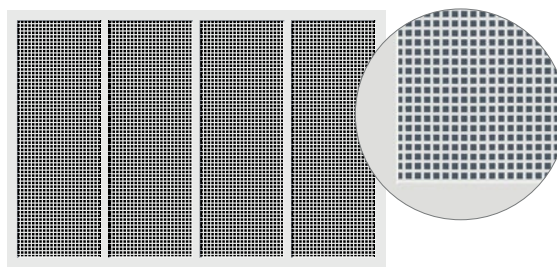

Styles 413 and 433
Internal perforated sheet infill with square recesses, ventilation cross-section 44.4%

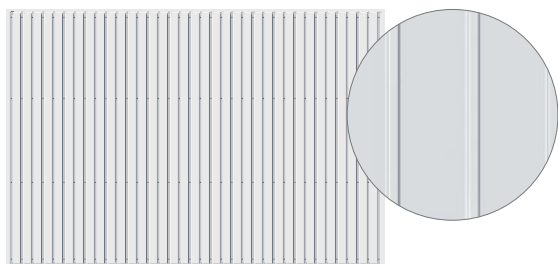

Style 402
Surface-mounted, ribbed sheet steel infill
(NEW. for ET 450: surface-mounted sheet steel infill)

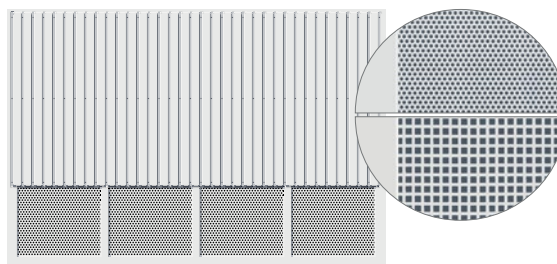

Style 414
Surface-mounted, ribbed sheet steel with perforated sheet infill, round or square, ventilation cross section 46.1% (round) or 44.4% (square)

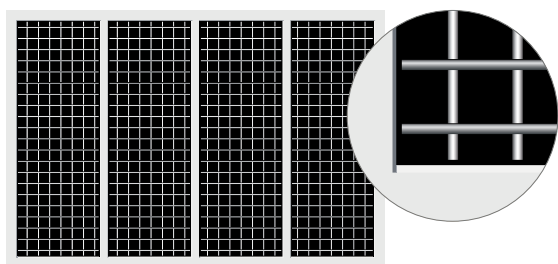

Style 403
Welded grille infill on the inside, ventilation cross-section 85%

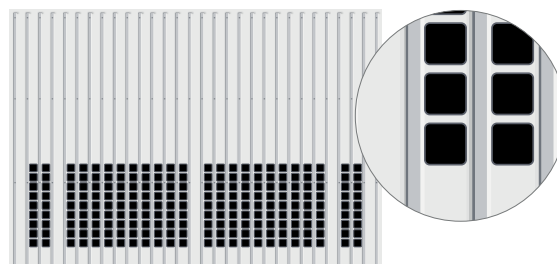

NEW. Style 414 (ET 450)
Surface-mounted, ribbed sheet steel with square perforation 50 x 50 mm in the bottom or top section (Fig. shows bottom section), ventilation cross-section 11.5%.

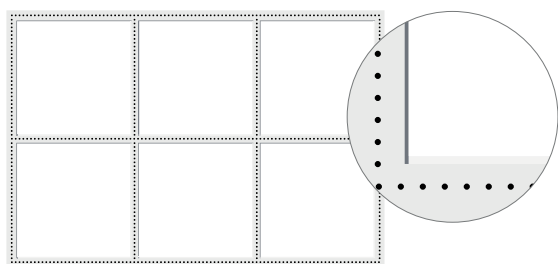

Style 405
Frames for surface-mounted, on-site cladding, Information on the max. infill weight can be found in the technical manual.

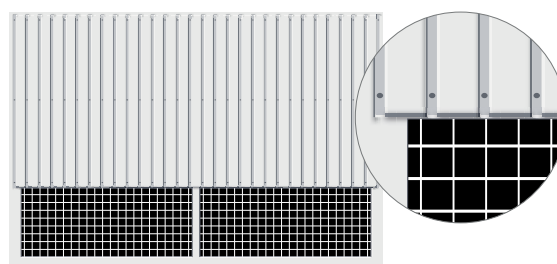

NEW. Style 416 (ET 450)
Surface-mounted, ribbed sheet steel with 50 x 50 mm mesh infill in the bottom or top section (Fig. shows bottom section), ventilation cross-section 23.2%

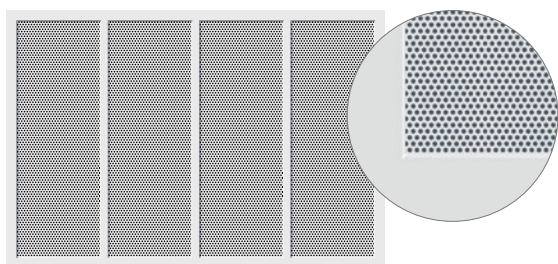

Styles 412 and 432
Internal perforated sheet infill
(Style 412 perforated steel sheet, style 432 perforated aluminium sheet) with round recesses, ventilation cross-section 46.1%

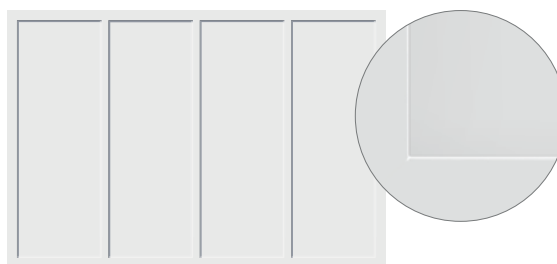

Style 420
Internal, smooth aluminium sheet infill
(NEW. for ET 450 internal, smooth sheet steel infill)

TRESPA® decor infills

For a harmonious appearance

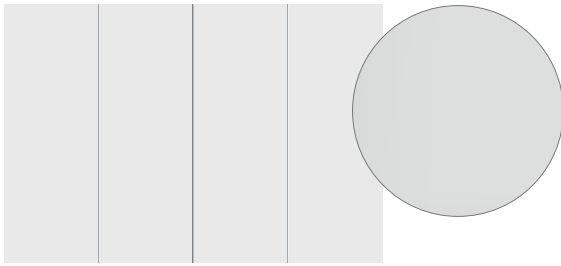

Style 422
Surface-mounted, smooth aluminium sheet

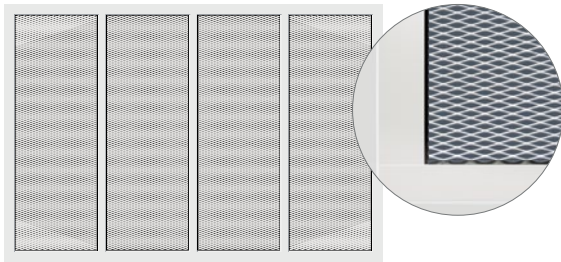

Style 440
Internal expanded mesh infill,
ventilation cross-section 50%

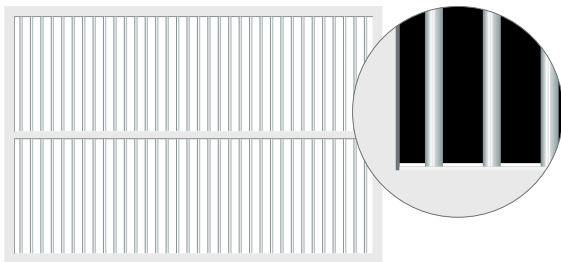

Style 470
Infill with aluminium bars 20 x 20 x 2 mm,
ventilation cross-section 80%

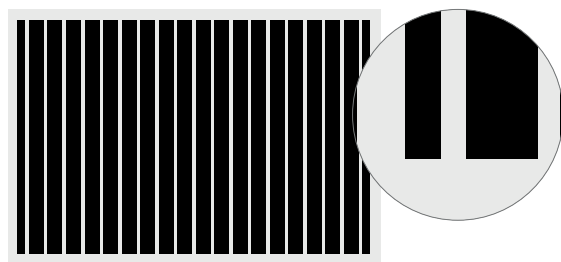

NEW. Style 470 (ET 450)
Infill with galvanized square tube bars
30 x 30 x 1 mm, ventilation cross-section 77%

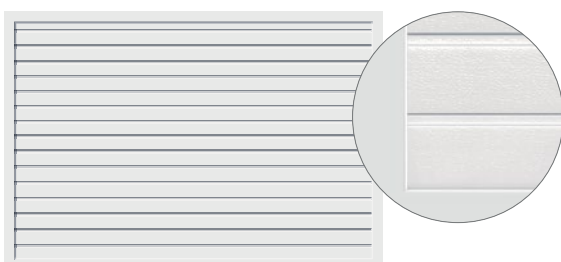

Style 480
Internal section infill also available with ventilation grille,
aluminium frame, glazing and expanded mesh infill

NEW. Style 497 with decorative laminates

For a harmonious facade view, the style 497 is available in 15 "Natural" and 28 "Wood" decors.

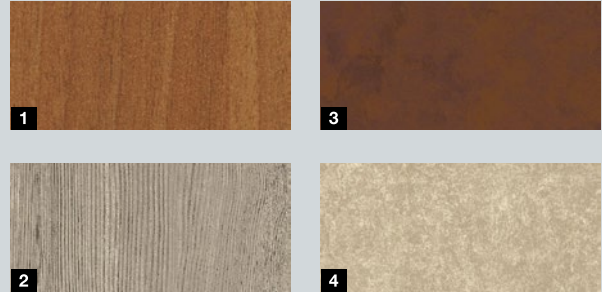

TRESPA® METEON® facade panels

- | | |
|-----------------------------------|---------------------------------------|
| 1 Italian Walnut NW08 Matt | 3 Hardened Brown NM05 matt |
| 2 Halmstad NW28 matt | 4 Natural Chalkstone NA12 matt |

For further information, see
www.trespa.com/en_GB/products/Naturals
www.trespa.com/en_GB/products/wood-decors



NEW. Style 497
Free choice of infill made of decorative laminates (HPL panels),
Wood and Natural styles (Fig. shows TRESPA® METEON® Halmstad NW 28 matt)

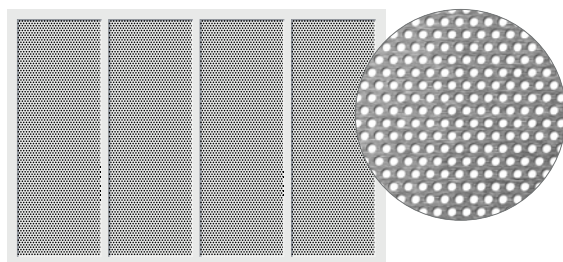

NEW. Style 498
Free choice of steel or aluminium infill



Style 499
Individual style, freely combined style variants or surface-mounted
infill (Figure shows Corten steel base plate)

Infills and colours

More scope for ideas

NEW. Infills for ET 500 / ST 500 style 498

For the style 498, 180 different infill types are available (perforated sheet and expanded mesh made of steel and aluminium, welded grille made of steel). They are also available in all colours.

For further information, see
<https://www.mevaco.de/en-US/>

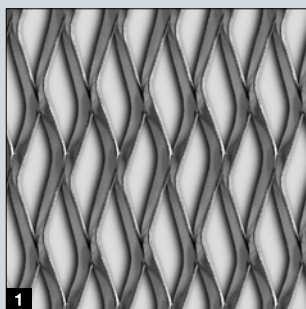

- 1 Shaft 62 × 22 × 6
- 2 Cross 11
- 3 Staggered round perforation 4 – 6

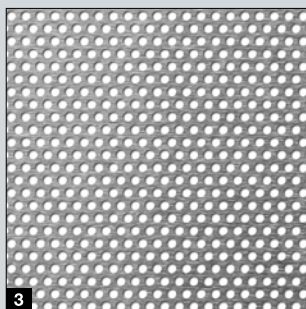
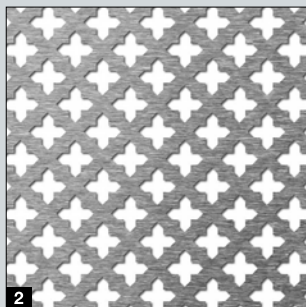

Colours N 500

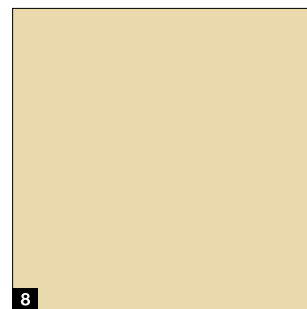
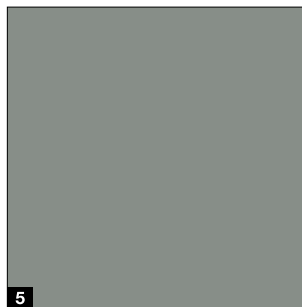
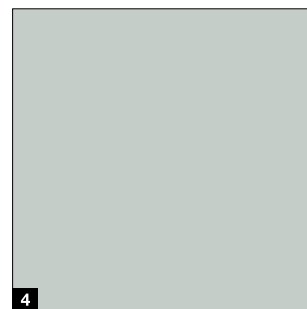
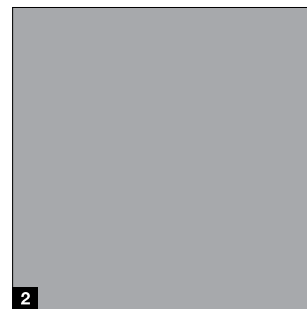
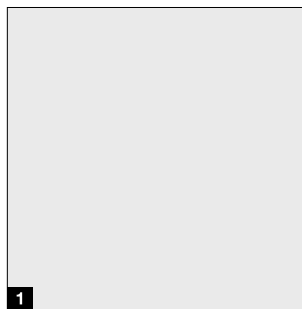

Standard colour

- 1 RAL 9016 Traffic white

Preferred colours

- 2 RAL 9007 Grey aluminium
- 3 RAL 8028 Terra brown
- 4 RAL 7040 Window grey
- 5 RAL 7035 Light grey
- 6 RAL 7016 Anthracite grey
- 7 RAL 6009 Fir green
- 8 RAL 1015 Light ivory

RAL to choose

All door types are optionally available in approx. 200 RAL colours as well as special colours.

Please note:

All colours based on RAL. The colours and surface finishes shown are subject to the limitations of the printing process and cannot be regarded as binding. Please consult with your local Hörmann sales partner.

Colours ET 450 / ET 500 / ST 500



Standard colour

- 1** RAL 9016 Traffic white (for ET 450)
- 2** RAL 9006 White aluminium (for ET 500, ST 500)

Preferred colours

- | | | |
|---|------------------------------------|----------------------------------|
| 1 RAL 9016 Traffic white ¹⁾ | 7 RAL 7040 Window grey | 13 RAL 5014 Pigeon blue |
| 2 RAL 9006 White aluminium ²⁾ | 8 RAL 7035 Light grey | 14 RAL 5011 Steel blue |
| 3 RAL 9007 Grey aluminium | 9 RAL 7030 Stone grey | 15 RAL 5003 Sapphire blue |
| 4 RAL 8028 Terra brown | 10 RAL 7016 Anthracite grey | 16 RAL 3003 Ruby red |
| 5 RAL 8003 Clay brown | 11 RAL 6009 Fir green | 17 RAL 1015 Light ivory |
| 6 RAL 8001 Ochre brown | 12 RAL 6005 Moss green | |

¹⁾ Preferred colour for ET 500 and ST 500

²⁾ Preferred colour for ET 450

Up-and-over door N 500

Equipment





Well thought-out door construction

The sturdy and open construction ensures precise and safe opening and closing. Thanks to the mechanical anti-lift kit of the operator, the door is also locked securely.

Harmonious door appearance **1**

For a harmonious door appearance, the door leaf and subframe are flush-fitting and have the same colour. The door can be fitted flush with the facade, in the reveal or behind it.

Safe opening mechanism **2**

Stable lever arms with ball-bearings and track rollers with ball-bearings allow the door to operate smoothly, safely and precisely. The specially dimensioned multiple spring assembly has two functions: it supports safe door opening and closing and at the same time prevents the door leaf from falling. The open design also minimises the risk of crushing.

Well-sealed **3**

Double seals on the door's bottom edge effectively prevent the ingress of leaves, hail and snow.

Convenience with operator

The N 500 up-and-over door can be equipped with SupraMatic E/P operators. If the door is being used as a collective garage door, the SupraMatic HT operator packages with internal or external control are required. These packages additionally include the photocell EL 301 as well as a spring assembly for a longer service life. No additional headroom is required for fitting the operator. Optionally, the door can be operated or additionally locked by hand using a handle **4**.

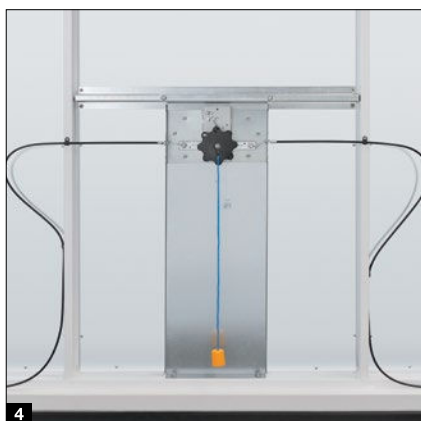

NEW. Non-protruding up-and-over door ET 450

Equipment





Continuous functionality even during heavy use

The low-maintenance door construction with wear-free counter weight technology ensures that the door opens and closes smoothly, quietly and safely. It is designed for at least 250,000 door cycles.

Smooth door travel without swivelling out the door leaf ¹

Thanks to the precise roller guiding in the guide rail, the door runs quietly and extremely precisely. If the door is fitted behind the opening or with a subframe, the ET 450 can be installed directly on the street or pavement, since the door leaf does not swivel out.

Space-saving fitting dimensions ²

The ET 450 requires little space. In combination with the SupraMatic HT 3 operator, the required headroom is only 120 mm. The sideroom is also space-saving, with a requirement of only 200 mm (fitting behind the opening). The low frame depth of a maximum of 530 mm also allows the space directly next to the door to be used as a parking space. The minimum distance back also creates more ceiling space.

Sturdy and safe construction ³

The entire door construction is extremely durable and requires little maintenance. The wear-free counter weight technology is designed for at least 250,000 door cycles. In addition, double pull cords ensure that the door leaf cannot fall. The leaf frame consists of 80 mm wide and 60 mm deep outer profiles. The subframe and the weight box are galvanized as standard and optionally available in the door colour.

Optimal safety with integrated photocell ⁴

The open construction offers maximum operational safety for daily use. Safety clearances between the door leaf and the building structure as well as at the bottom and side edges provide reliable protection against trapping. A special EPDM bottom profile shape with active safety edges also helps to ensure this. Side and top EPDM seals are optionally available. The two integrated photocells for personal protection are already pre-assembled in the door frame.

The use of a wicket door in the ET 450 is not possible.

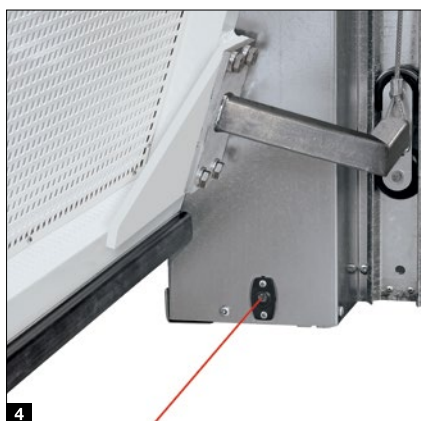

NEW. Non-protruding up-and-over door ET 500 Series 3

Equipment





Lasting functional safety even at high frequencies

The low-maintenance door construction with wear-free counter weight technology opens and closes smoothly, quietly and safely. It is designed for at least 250000 door cycles. Due to the limited frame depth, the space directly next to the door can also be used as a parking space.

Quiet door travel without swivelling out of the door leaf ¹

Precise roller guiding in the guide rail allows the door to run quietly and extremely precisely. If the door is fitted behind the opening or with a subframe, the ET 500 Series 3 can be fitted directly adjacent to the street or pavement, since the door leaf does not swivel out.

Compact fitting dimensions ²

The ET 500 Series 3 requires hardly any space: In combination with an operator, the required headroom is only 120 mm (SupraMatic HT) or 160 mm / 200 mm (ITO 500 FU). The same applies to sideroom: The space requirement here is 200 mm (fitting behind the opening). The small frame depth of max. 530 mm means that the space directly next to the door can also be used as a parking space. Thanks to the minimal distance back there is also more ceiling space.

Sturdy and safe construction ³

The entire door construction is extremely long-lasting and low-maintenance: the wear-free counter weight technology is designed for at least 250000 door cycles. Double pull cords also prevent the door leaf from falling. The leaf frame is made of 80 mm-wide and 90 mm-deep outer profiles. The subframes and the weight box are available in the door colour as standard.

Exemplary safety thanks to two integrated photocell sets ⁴

The open construction features the greatest operational safety in tough everyday operation: A safety clearance between the door leaf and building structure as well as on the bottom and side edges ensures a reliable anti-trap protection. Side and top EPDM seals and the EPDM bottom profile with active safety edge are standard equipment. The two integrated photocells for protecting people are already pre-assembled in the door frame and can be installed on the operator in just a few simple steps.

The use of a **wicket door in the ET 500** is possible. Further information on wicket doors can be found on page 34.

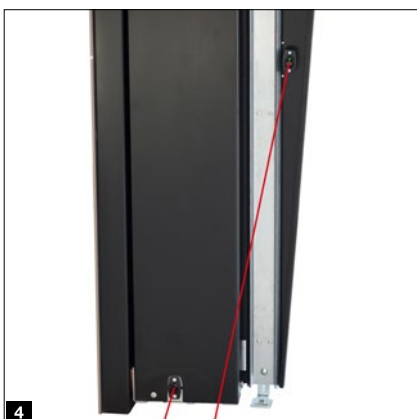

Sliding door ST 500

Equipment

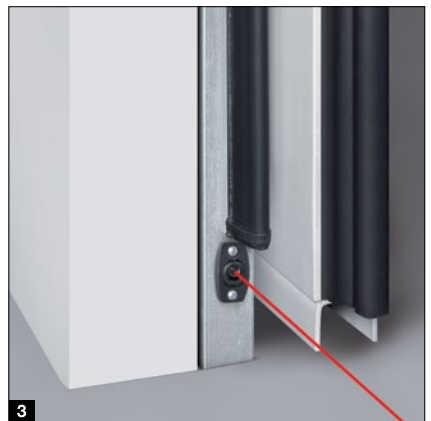
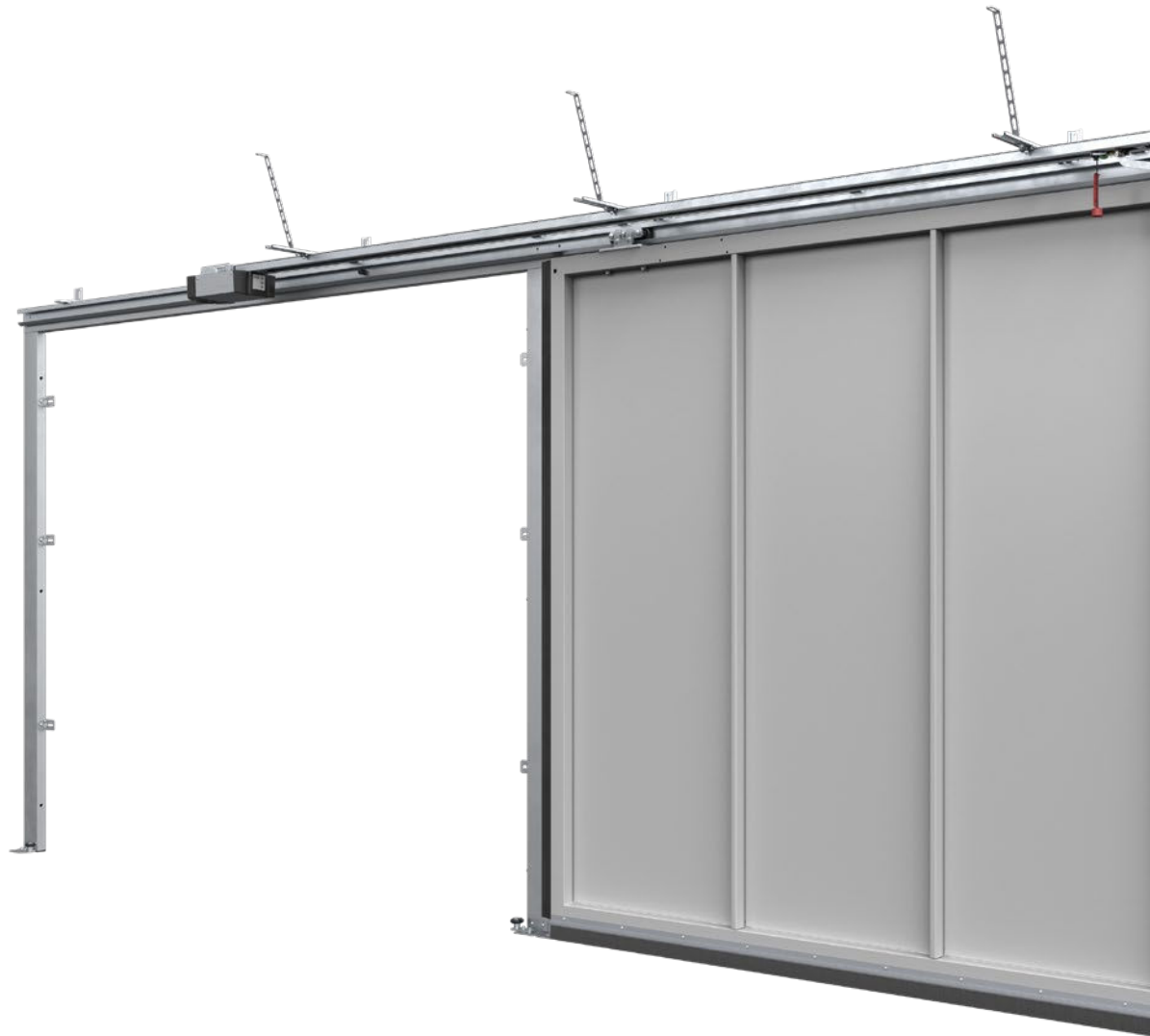



Low space requirements for optimised use of space

The collective garage sliding door ST 500 requires very little fitting depth. As a result, parking spaces can also be used directly next to the door. Thanks to the narrow subframe, it can also be fitted with very low headroom.

Particularly space-saving ¹

The small fitting depth of 450 mm incl. operator allows fitting where suspensions have been fitted to the garage ceiling. Thanks to the standard subframe, fitting is even possible if no lintel is available.

Sturdy and safe construction

The entire door construction is extremely long-lasting, maintenance-free and designed for at least 250000 door cycles.

Quiet and safe door travel ²

Twin rollers in the upper guide rail and guide rollers with ball-bearings at the floor offer smooth, quiet door travel and almost silent opening and closing. As a result, the door is securely guided over its entire travel range, even in the parking area.

Exemplary safety ³

Safety profiles at the closing edge of the door as a standard feature and photocell pre-assembled in the door opening as standard offer full protection against injuries and material damage.

Side doors and wicket doors

Easy access to the garage

Side doors **1**

Equipment

- Single-leaf door set
- 80 mm frame construction, galvanized and with powder-coated primer in White aluminium, RAL 9006
- 60 mm frame profile made of galvanized square tubes, powder-coated in door leaf colour
- NT ET 500: concealed hinges **3**
- NT N 500: 3-way adjustable aluminium hinges **3**
- Lever handle set **6**
- Optional: integrated door closer with slide rail, with / without hold-open device (NT ET 500) **4**
- Optional: door closer with slide rail, with / without hold-open device (NT N 500) **7**
- Flush-fitting appearance and all-round sealing (NT ET 500) **7**

Wicket doors **2**

Door versions

- Non-protruding up-and-over door ET 500, sliding door ST 500 and up-and-over door N 500
- Styles 412, 413, 432, 433, 420, 422, 470, 480, 405, 400, 497¹⁾, 498¹⁾ and 499

Equipment

- 80 mm frame construction, galvanized and with powder-coated primer in White aluminium, RAL 9006
- ET 500: lever handle set **6** and concealed hinges **3**
- ST 500: lever handle set (interior) **6** or pull handle (exterior) **5** and concealed hinges **3**
- Invisible integrated door closer with slide rail with / without hold-open device **4**
- Flush-fitting appearance and all-round sealing **7**
- Optional: retractable bottom seal **8**

Fittings

- Mortice lock with profile cylinder
- Optional: double cylinder lock **9**
- Offset lever handle set, with oval rose escutcheons made of black plastic **10**
- On request also available as lever / knob handle sets
- Optionally available in natural finish cast aluminium **11**, polished stainless steel **12** or brushed stainless steel **13**

¹⁾ only ET 500-3



Side door
NT ET 500

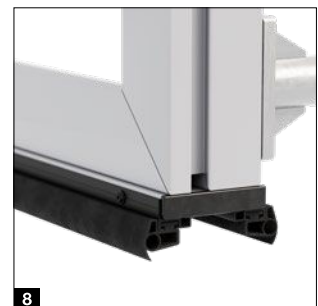



Side door
NT N 500



Wicket door

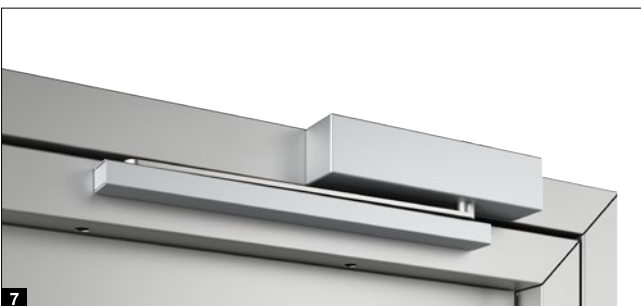
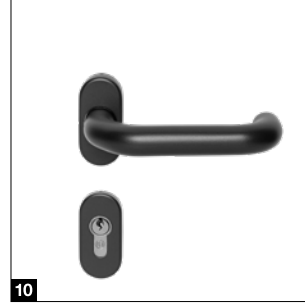

Operators

SupraMatic 4

Supra-fast door opening and smart additional functions

- Up to 75% faster opening speed¹⁾ up to 25 cm/s
- Smart operation with the Hörmann BlueSecur app
- Convenient garage ventilation
- Additional opening height
- Up to 3 times (SupraMatic E) or 5 times¹⁾ (SupraMatic P) brighter LED lighting
- Easy-to-use programming thanks to double 7-segment display
- High-quality stainless steel operator cover
- Networked with Smart Home systems via the standard HCP interface²⁾
- Low power consumption in standby below 1 watt

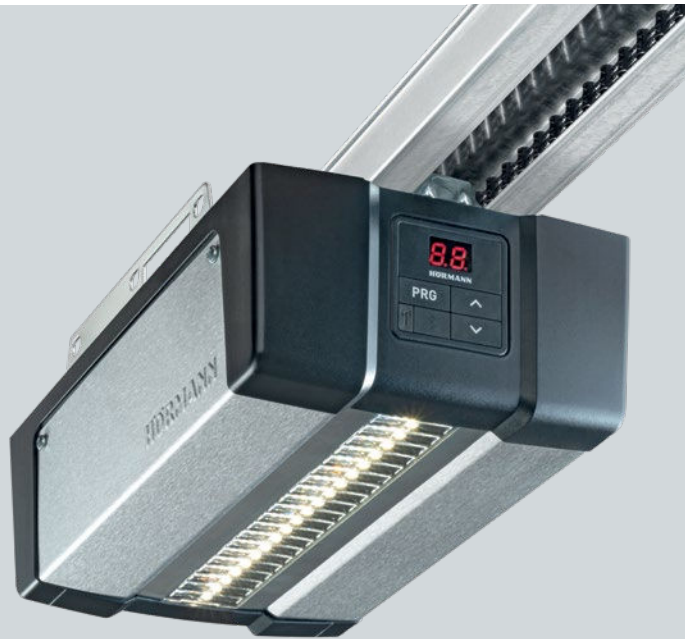

 **BiSecur**

Standard 4-button hand transmitter HSE 4 BS, textured surface black with chrome caps

Garage door operators	SupraMatic E	SupraMatic P	SupraMatic HT 3
Up-and-over door N 500	○	○	○
Non-protruding up-and-over door ET 450 / ET 500 / sliding door ST 500	-	-	●
Bluetooth receiver for Hörmann BlueSecur app	Integrated, can be switched on and off	Integrated, can be switched on and off	Optional (HET-BLE)
HCP bus connection	Integrated	Integrated	Integrated ²⁾
Cycles per day / hour	25 / 10	50 / 10	150 / 20
Pull and push force	650 N	750 N	1000 N
Peak force	800 N	1000 N	1200 N
Max. opening speed	25 cm/s	28 cm/s	22 cm/s
Lighting	20 LEDs	30 LED chase light	-
Max. door width	5500 mm	6000 mm	6000 mm
Max. door surface	13.75 m ²	15 m ²	17.25 m ²

● = Standard ○ = Optional - = Not possible

¹⁾ In comparison with the ProMatic Series 3

²⁾ With operator SupraMatic HT 3 not compatible with KNX gateway

Powerful operator with soft start and soft stop

- Fast opening speed of up to 0.5 m/s
- Soft start and soft stop for quiet and gentle door travel
- Optional 2nd opening height
- Emergency / maintenance release as standard
- Emergency / maintenance release via Bowden cable on the slide carriage (optionally possible from the outside)
- Optionally secured release on the inside / outside (ideal for use on facade doors)
- Settings on a separate control via a control panel
- Automatic timer¹⁾
- Prepared for traffic control¹⁾
- Integrated timer function²⁾
- Adaptive door action check with intelligent speed control



Hörmann BlueControl app

For smart set-up and adjustment of operator control

Garage door operators

ITO 500 FU

Up-and-over door N 500	–
Non-protruding up-and-over door ET 450	–
Non-protruding up-and-over door ET 500 / sliding door ST 500	○
Bluetooth receiver for Hörmann BlueControl app	Integrated
Bluetooth receiver for Hörmann BlueSecur app	Optional (HET-BLE)
HCP bus connection	Integrated
Cycles per day / hour	450 / 30
Pull and push force	1500 N
Peak force	2000 N
Max. opening speed	50 cm/s
Max. door width	6000 mm
Max. door surface	18 m ²

● = Standard ○ = Optional – = Not possible

¹⁾ Only in combination with an activating kit for warning lights and photocell / light grille

²⁾ With control 560



The control for the operator

Using the menu on the optimally matched control for the ITO 500 FU, you can quickly and easily set, for example, desired hold-open phases and visual indicators of warning lights.



Activating kits for warning lights

Secure warning lights and control the entrance and exit of the door system. Yellow warning lights alert during door travel, red / green activating kits for warning lights serve as a visual indicator for controlling the entrance and exit.

Accessories

Hand transmitter



HS 5 BS
4 button functions plus query button,
high-gloss surface black or white



HS 5 BS
4 button functions plus query button,
textured surface matt black



HS 4 BS
4 button functions,
textured surface matt black



HS 1 BS
1 button function,
textured surface matt black



HSE 1 BS
1 button function, including
eyelet for key ring,
textured surface matt black



HSE 4 BS
4 button functions, incl. eyelet
for key ring, textured surface
matt black with chrome or
plastic caps



HSE 4 BS
4 button functions, incl. eyelet
for key ring
High-gloss surface with chrome
caps, colours (shown from left):
White, Anthracite grey,
Frozen grey, Classic grey,
Carbon, Silver



RSC2
2 button functions, including
eyelet for key ring,
textured surface black matt,
rolling code radio system
(433 MHz)



HSD 2-C BS
High-gloss chrome,
2 button functions, can
also be used as a key ring



HSZ 1 BS / HSZ 2 BS
1 or 2 button functions,
for insertion in vehicle
cigarette lighter



Hand transmitter station
In high-gloss surface black or
white, textured surface black matt,
for HS 5 BS, HS 4 BS, HS 1 BS



Hand transmitter holder
For wall fitting or fastening to the
sun visor of a car, transparent,
for HS 5 BS, HS 4 BS, HS 1 BS as
well as HSE 1 BS and HSE 4 BS

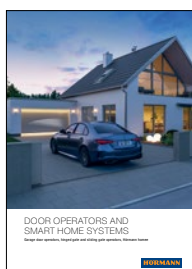

The complete range of accessories can be found in the door operators and Smart Home systems brochure.



**Radio code switch
FCT 3 BS**
3 functions, with illuminated buttons, recessed or surface-mounted fitting possible, plastic housing in Light grey RAL 7040 (also available with 10 functions and hinged cover, painted in White aluminium RAL 9006)



**Radio code switch
FCT 10 BS**
10 functions, with illuminated buttons and hinged cover, recessed or surface-mounted fitting possible, plastic housing painted in White aluminium RAL 9006



**Radio finger-scan
FFL 25 BS**
2 functions and up to 25 fingerprints, with hinged cover, recessed and surface-mounted fitting possible, plastic housing painted in White aluminium RAL 9006

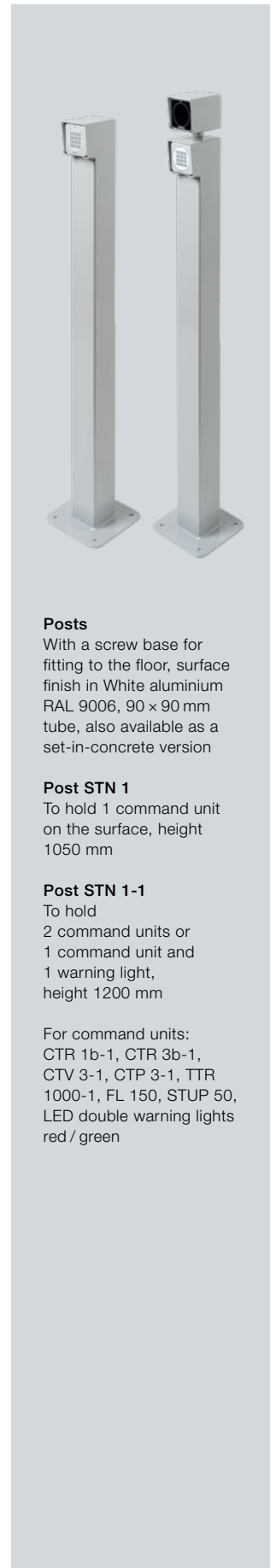

Posts
With a screw base for fitting to the floor, surface finish in White aluminium RAL 9006, 90 x 90 mm tube, also available as a set-in-concrete version

Post STN 1
To hold 1 command unit on the surface, height 1050 mm

Post STN 1-1
To hold 2 command units or 1 command unit and 1 warning light, height 1200 mm

For command units:
CTR 1b-1, CTR 3b-1, CTV 3-1, CTP 3-1, TTR 1000-1, FL 150, STUP 50, LED double warning lights red / green

Button



**Transponder key switch
TTR 1000-1**
1 function, 1000 teachable keys, scope of delivery: 1 key and 1 card (more on request), zinc die-cast housing in White aluminium RAL 9006



**Code switch
CTP 3-1**
3 functions, with illuminated lettering and touch-sensitive black surface, zinc die-cast housing in White aluminium RAL 9006



**Code switch
CTR 1b-1 / 3b-1**
1 or 3 functions, plastic housing in Light grey RAL 7040



**Code switch
CTV 3-1**
3 functions, particularly robust with metal keypad, zinc die-cast housing in White aluminium RAL 9006 with stainless steel panel



**Finger-scan
FL 150**
2 functions, control via fingerprint, up to 150 savable fingerprints, zinc die-cast housing in White aluminium RAL 9006 with stainless steel panel



Key switch
1 STUP 50
2 STAP 50
Recessed version and surface-mounted version, incl. 3 keys, zinc die-cast housing in White aluminium RAL 9006 with stainless steel panel

Dimensions and technical manual

Size ranges

Styles 412, 413

Doors with perforated steel sheet infill

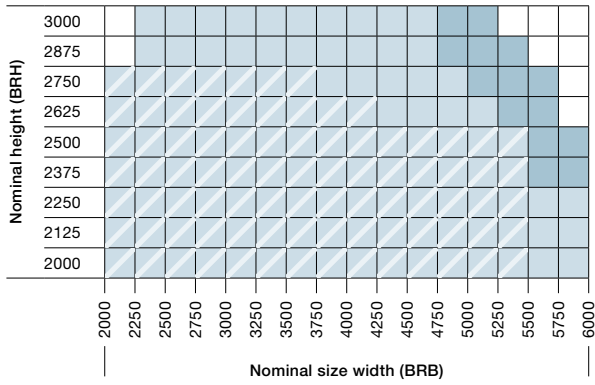

Styles 432, 433

Doors with aluminium perforated sheet infill

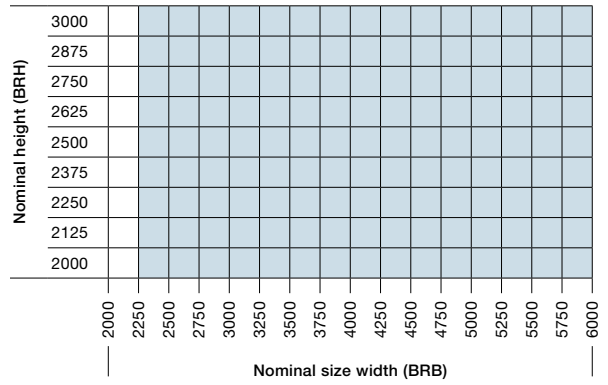

Style 420

Doors with internal aluminium sheet infill

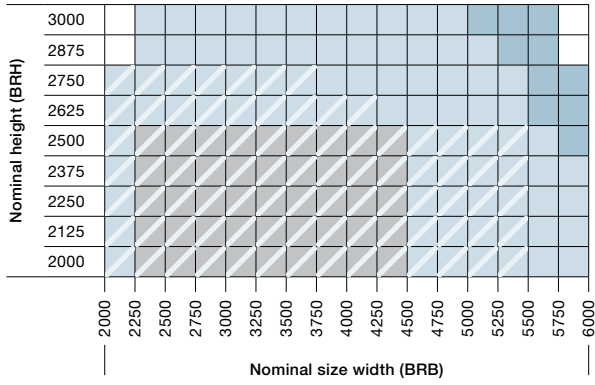

Style 480

Doors with section infill

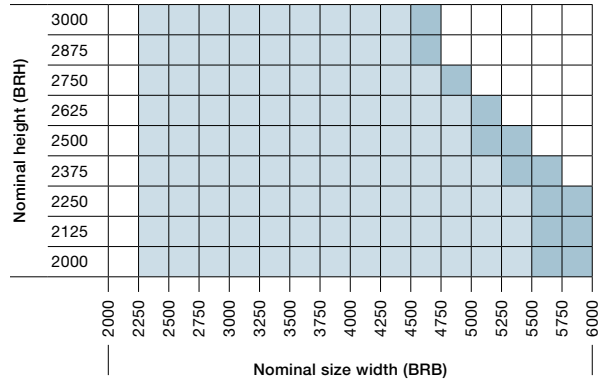

Style 402

Doors with surface-mounted ribbed sheet infill

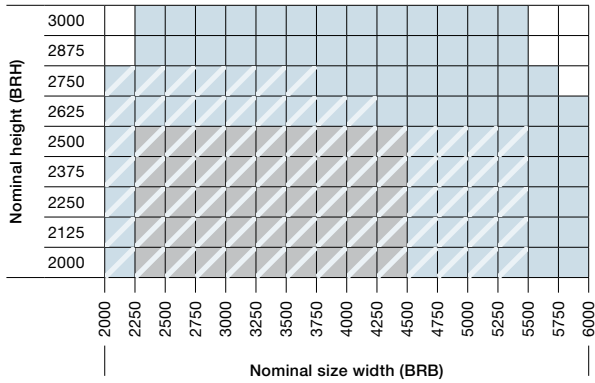

Style 414



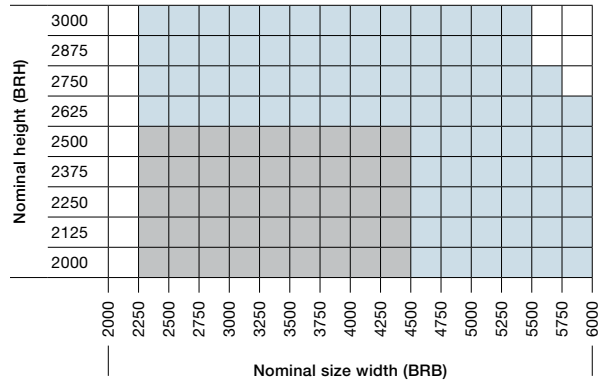

Doors with surface-mounted ribbed sheet infill

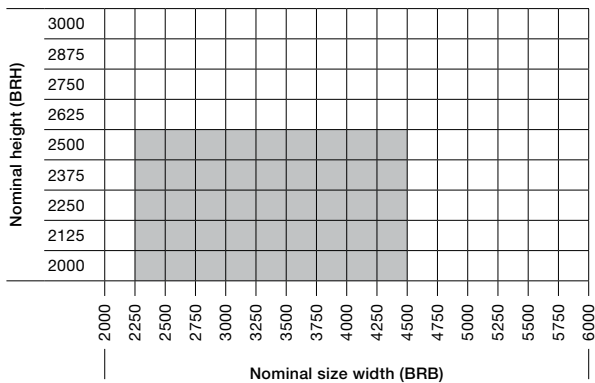

Style 416

Doors with surface-mounted ribbed sheet infill and mesh infill



-  ET 500 Series 3
-  ET 450
-  ST 500
-  N 500

Dimensions in mm

Style 422

Doors with surface-mounted aluminium sheet infill

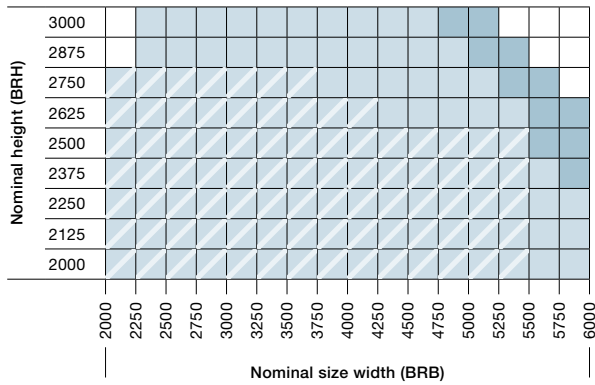
**Style 400**

Doors for on-site infill inside the frame

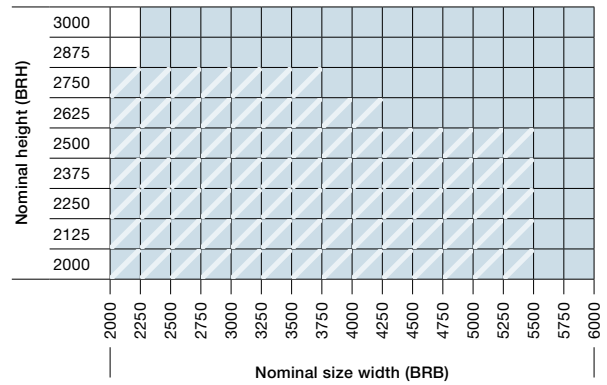
**Style 405**

Doors for on-site surface-mounted infill

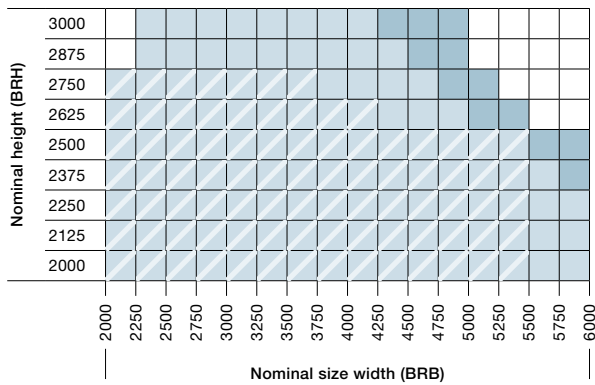
**Style 403**

Doors with welded grille infill on the inside

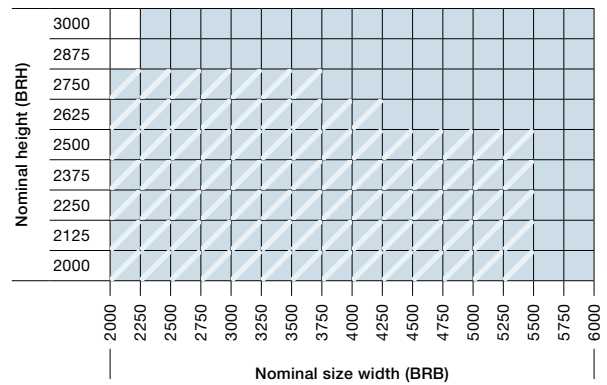
**Style 440**

Doors with expanded mesh infill on the inside

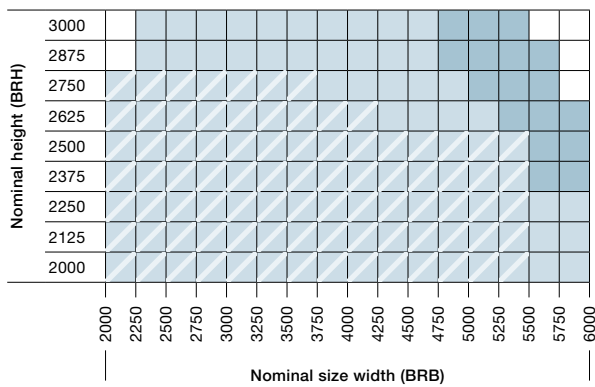
**Style 470**

Infill with aluminium rods 20 x 20 x 2 mm

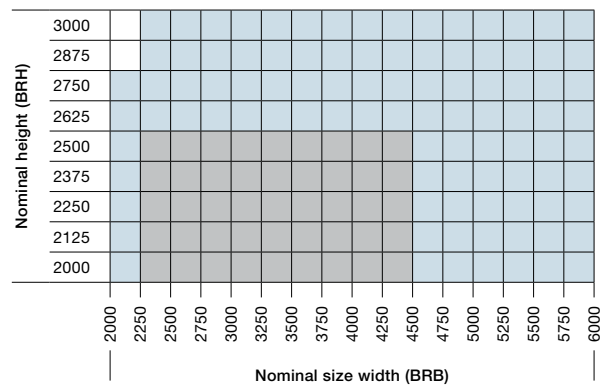
**Style 499**

Doors with combined infill

Dimensions in mm

Note

For the maximum infill weight please see the technical manual.

Dimensions and technical manual

NEW. ET 450, ET 500-3

NEW. ET 450 fitting behind the opening

Vertical view

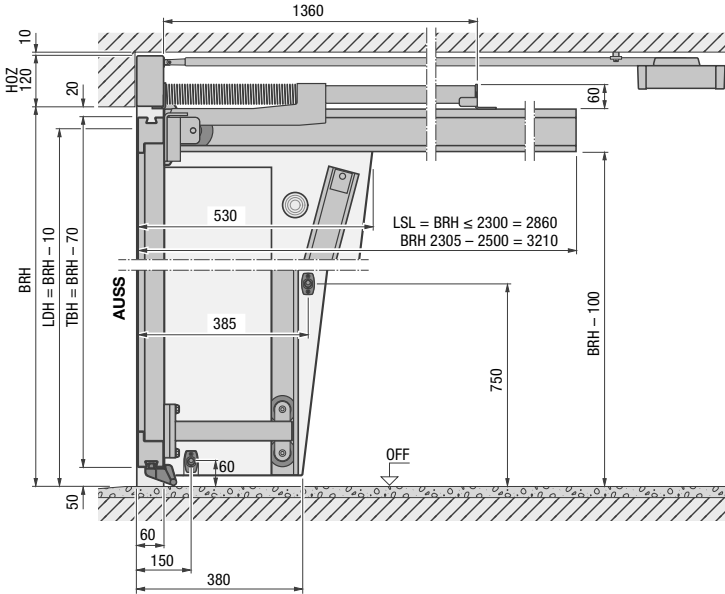

Horizontal view

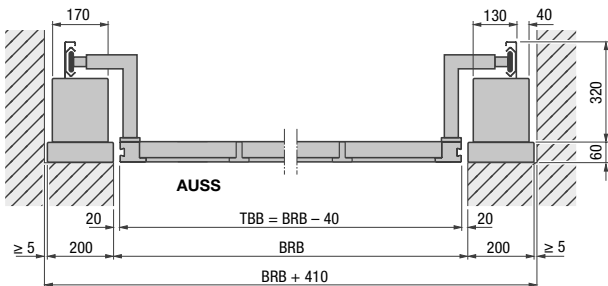

NEW. ET 450 fitting in the opening (flush-fitting)

Vertical view

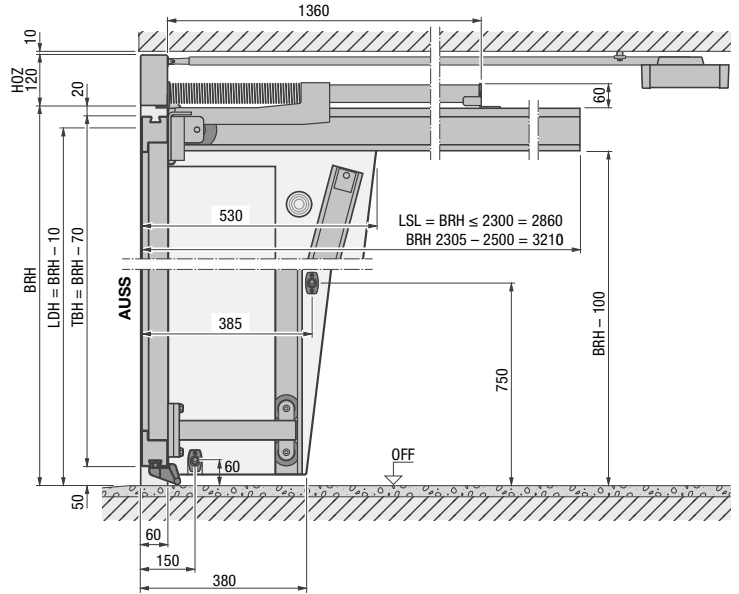

Horizontal view

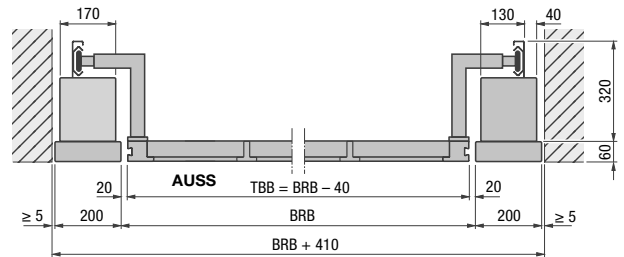

Explanations

- AUSS Exterior
- BRB Nominal size width = ordering size
- BRH Nominal height = ordering size
- HOZ Transom light frame height
- LDH Clear passage height
- LSL Track length
- OFF Finished floor level
- TBB Door leaf width
- TBH Door leaf height

ET 450

Distance back with operator

SupraMatic HT:	
BRH 2000 - 2200	3260
BRH 2205 - 2450	3510
BRH 2455 - 2500	4185

Required headroom SB

SupraMatic HT

For fitting with lintel, the minimum headroom must be HOZ + 10 mm.

Clear passage height LDH

BRB < 6000 = BRH - 10

Clear opening width LB

BRB = LB 2250 - 4500

ET 500-3 fitting behind the opening

Vertical view

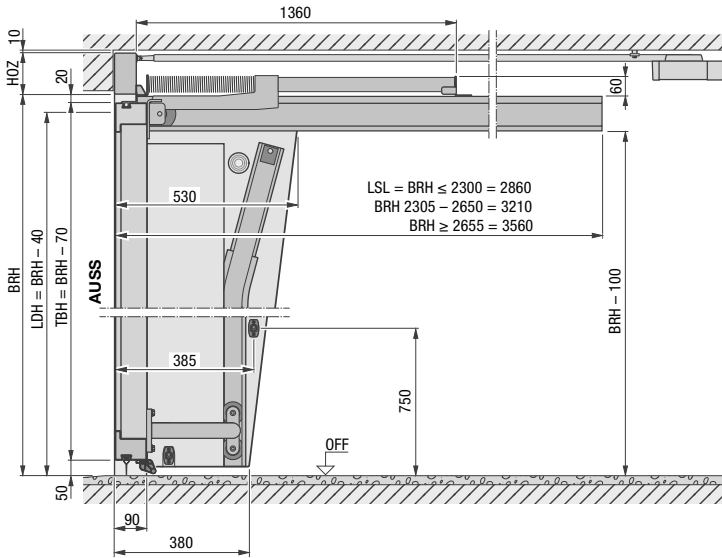

Horizontal view

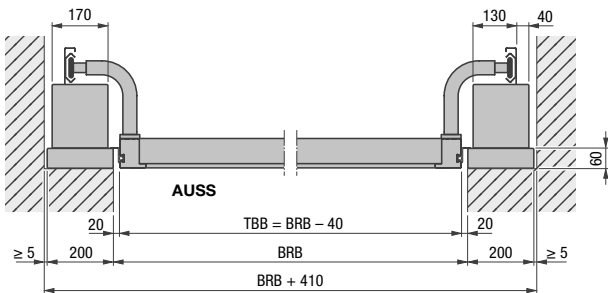

ET 500-3 fitting in the opening (flush-fitting)

Vertical view

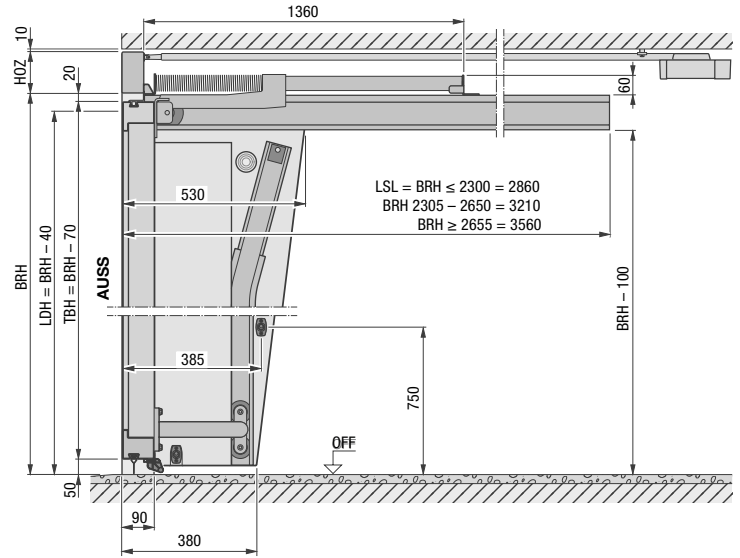

Horizontal view

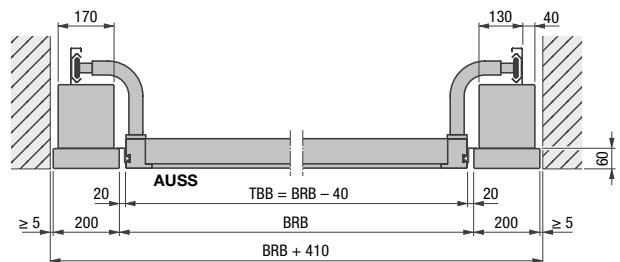

Explanations

AUSS	Exterior
BRB	Nominal size width = ordering size
BRH	Nominal height = ordering size
HOZ	Transom light frame height
LDH	Clear passage height
LSL	Track length
OFF	Finished floor level
TBB	Door leaf width
TBH	Door leaf height

ET 500-3

Distance back with operator

SupraMatic HT:	
BRH 2000 - 2200	3260
BRH 2205 - 2450	3510
BRH 2455 - 3000	4185
ITO 500 FU:	
BRH 2000 - 2650	3900
BRH 2655 - 3000	4900

Required headroom SB

SupraMatic HT / ITO 500 FU	
For fitting with lintel, the minimum headroom must be HOZ + 10 mm.	
Clear opening height LH	
BRH = LH	2000 - 3000

Clear passage height LDH

BRB < 6000	= BRH - 40
With wicket door	= BRH - 40

Side space requirement SPB

ET 500	Behind the opening 200 mm
--------	---------------------------

Clear opening width LB

BRB = LB	2250 - 6000
----------	-------------

Swivelling range AB with flush-fitting installation

ET 500	0
--------	---

Frame depth ZT-a / ZT-b

ET 500	530 / 380
--------	-----------

Dimensions in mm

Dimensions and technical manual

ST 500, N 500

ST 500 fitting behind the opening

Vertical view

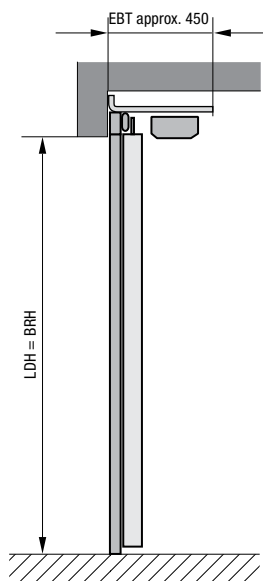

Horizontal view

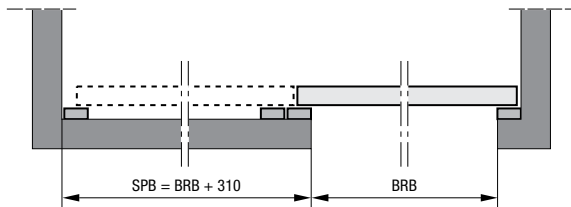

ST 500

Nominal height BRH = clear opening height LH
BRH 2000 – 3000

Nominal size width BRB = clear opening width LB
BRB 2250 – 6000

Clear passage width LDB
(depending on the fitting situation)
LDB = BRB – 60

Dimensions in mm

N 500 fitting behind the opening

Vertical view

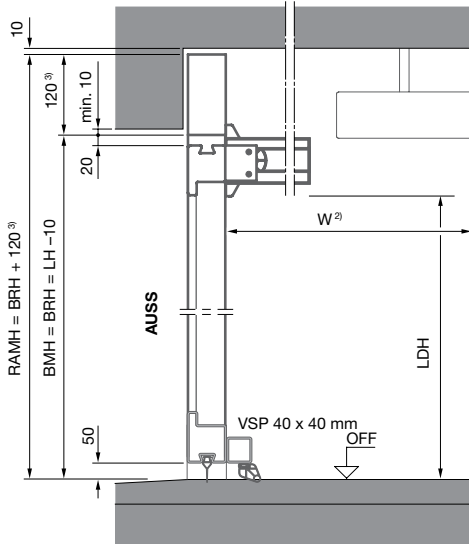

- Clear passage height up to BRB 3995 mm = BRH - 130 mm
- Clear passage height from BRB 4000 mm = BRH - 170 mm

N 500 fitting in the opening (flush-fitting with the facade)

Vertical view

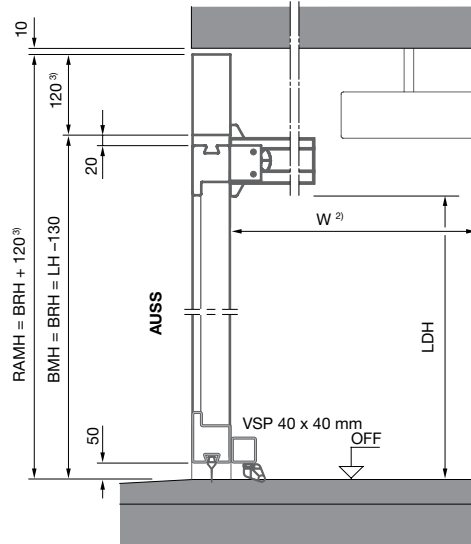

- Clear passage height up to BRB 3995 mm = BRH - 130 mm
- Clear passage height from BRB 4000 mm = BRH - 170 mm

Horizontal view

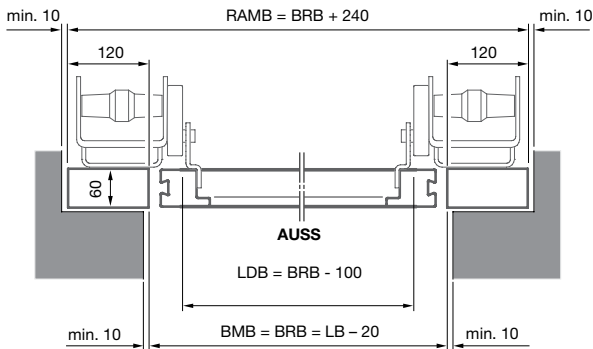

- 3) 120 mm infill thickness max. 20 mm
160 mm infill thickness max. 45 mm

Horizontal view

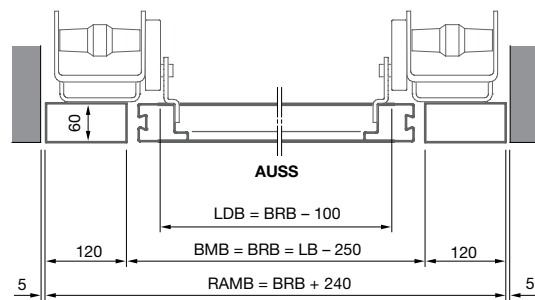

N 500

Overall length with operator GLA

SupraMatic HT:

BRH < 2500 3200

BRH < 2750 3450

Clear passage height LDH

BRB < 4000 = BRH - 130

BRB ≥ 4005 = BRH - 170

Clear passage height LDB

LDB = BRB - 100

Dimensions in mm

Note

For further information, please see the technical manual or contact your Hörmann sales partner.

Dimensions and technical manual

Wicket and side doors

ET 500 with wicket door

Vertical view

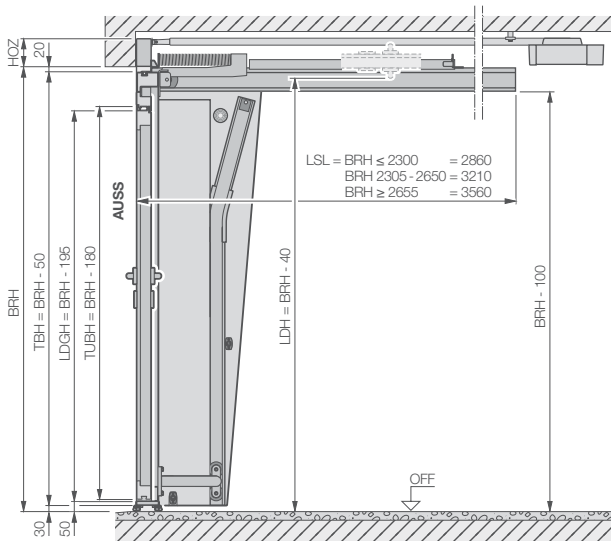

Horizontal view

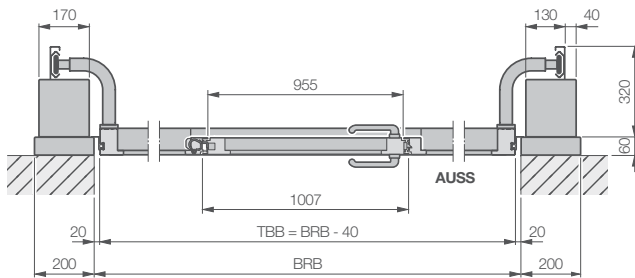

ST 500 with wicket door

Vertical view

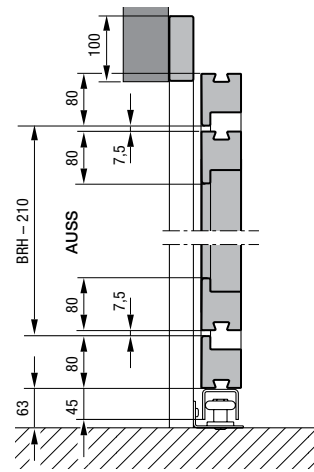

Horizontal view

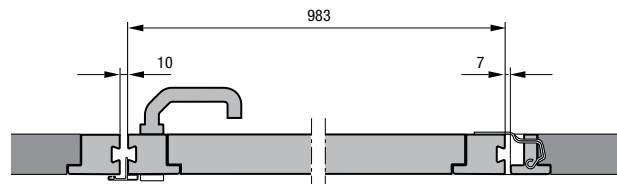

Explanations

- AUSS** Exterior
- BRB** Nominal size width = ordering size
- BRH** Nominal height = ordering size
- LDH** Clear passage height
- LDGH** Clear passage height
- LSL** Track length
- OFF** Finished floor level
- TBB** Door leaf width
- TBH** Door leaf height
- TUBH** Door leaf height
- Y** Thickness of surface-mounted infill

Note

For further information, please see the technical manual or contact your Hörmann sales partner.

Dimensions in mm

Side door fitting in the opening

Vertical view

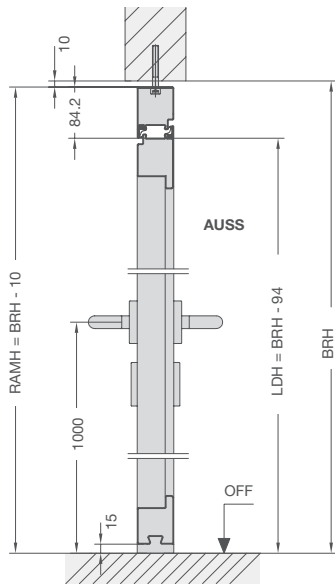

Side door fitting behind the opening

Vertical view

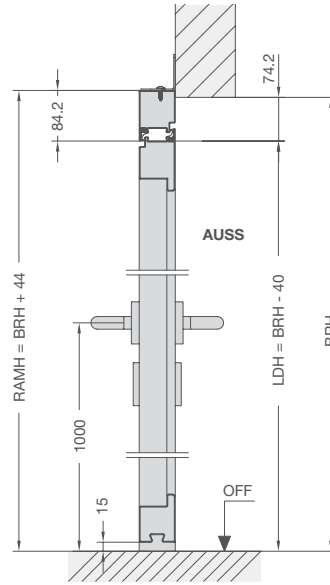

Horizontal view

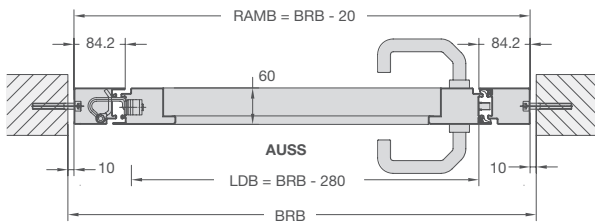

Horizontal view

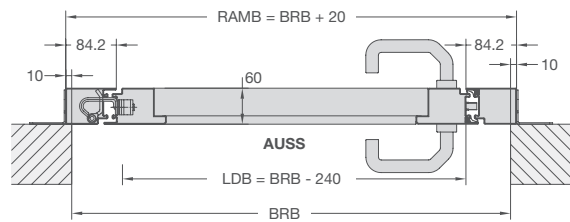

Clear passage width at an opening angle of 90°

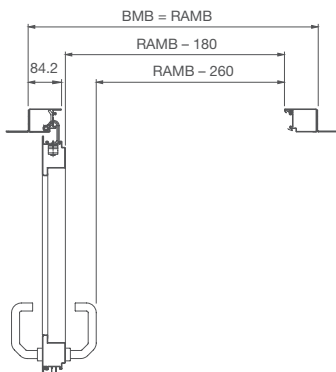

Explanations

- BRB** Nominal size width
- BRH** Nominal size height
- LDB** Clear passage width
- LDH** Clear passage height
- RAMB** Overall frame dimension width = ordering size
- RAMH** Overall frame dimension height = ordering size

Clear passage height LDH

Max. 2940 mm

Clear passage width LDB

Max. 1363 mm

Dimensions in mm

Everything from a single source for residential and commercial construction

Our large product range offers the right solution for any requirement. All products are optimally adjusted to work together, ensuring high functional safety. This makes us a strong, future-oriented partner for residential and commercial construction projects.

**INDUSTRIAL DOORS. LOADING TECHNOLOGY. SLIDING DOORS.
CONSTRUCTION PROJECT DOORS. PERIMETER PROTECTION SYSTEMS.**



Some of the products shown feature special equipment and do not always correspond to the standard versions. The surface finishes and colours shown are subject to the limitations of the printing process and cannot be regarded as binding. All RAL colours are based on the respective RAL colour chart. All rights reserved. No part may be reproduced without our prior permission. Subject to changes.